

**3 TERMINAL 1.5A POSITIVE VOLTAGE REGULATORS**

**DESCRIPTION**

The UTC78XX series of three-terminal positive regulators are available in TO-220 package and with several fixed output voltage, making them useful in a wide range of application. Each type employs internal current limiting, thermal shut-down and safe area protection, making it essentially indestructible. If adequate heat sinking is provided, they can deliver over 1.5A output current. Although designed as fixed voltage regulators, these devices can be used with external components to obtain adjustable voltage and currents.

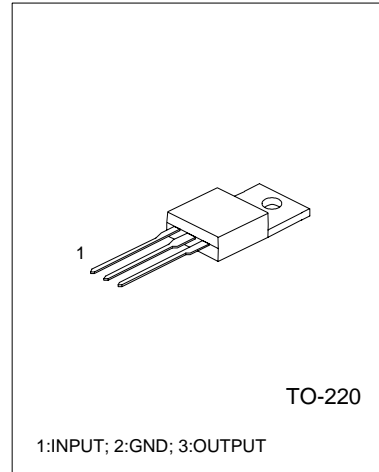

**FEATURES**

- \*Output current up to 1.5A
- \*5V;6V;8V;9V;10V;12V;15V;18V;24V output voltage available
- \*Thermal overload protection
- \*Short circuit protection
- \*Output transistor SOA protection

**BLOCK DIAGRAM**

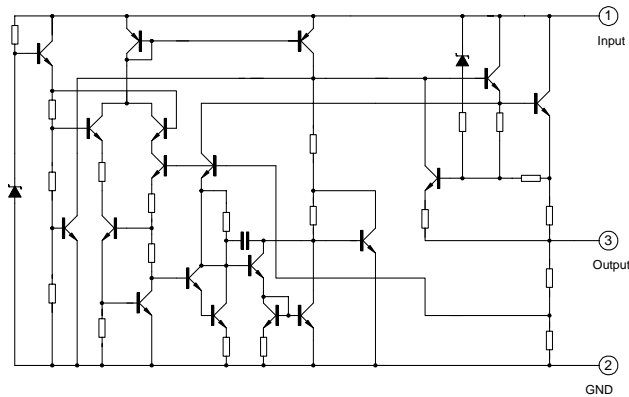

**ABSOLUTE MAXIMUM RATINGS**(Ta=25°C)

Characteristic	Symbol	Value	Unit
Input voltage (for Vo=5V to 18V)	Vi	35	V
(forVo=24V)		40	V
Thermal resistance junction-air	RθJA	65	°C/W
Thermal resistance junction-cases	RθJC	5	°C/W
Operating Temperature	Topr	0~ +125	°C
Storage Temperature	Tstg	-65 ~ +150	°C



**UTC7805 ELECTRICAL CHARACTERISTICS**(Refer to test circuits,  $0 < T_j < 125^\circ\text{C}$ ,  $I_o = 500\text{mA}$ ,  $V_i = 10\text{V}$ ,  $C_i = 0.33\mu\text{F}$ ,  $C_o = 0.1\mu\text{F}$ , unless otherwise specified)

Characteristic	Symbol	Test Conditions	Min	Typ	Max	Units
Output voltage	$V_o$	$T_j = 25^\circ\text{C}$	4.8	5.0	5.2	V
		$5.0\text{mA} < I_o < 1.0\text{A}$ , $P_o < 15\text{W}$ $V_i = 7.5\text{V}$ to $20\text{V}$	4.75	5.00	5.25	V
Line regulation	$\Delta V_o$	$T_j = 25^\circ\text{C}$ , $V_i = 7.5\text{V}$ to $25\text{V}$		4.0	100	mV
		$T_j = 25^\circ\text{C}$ , $V_i = 8\text{V}$ to $12\text{V}$		1.6	50	mV
Load regulation	$\Delta V_o$	$T_j = 25^\circ\text{C}$ , $I_o = 5.0\text{mA}$ to $1.5\text{A}$		9	100	mV
		$T_j = 25^\circ\text{C}$ , $I_o = 250\text{mA}$ to $750\text{mA}$		4	50	mV
Quiescent current	$I_Q$	$T_j = 25^\circ\text{C}$		5.0	8	mA
Quiescent current change	$\Delta I_Q$	$I_o = 5\text{mA}$ to $1.0\text{A}$		0.03	0.5	mA
		$V_i = 8\text{V}$ to $25\text{V}$		0.3	0.8	mA
Output voltage drift	$\Delta V_o / \Delta T$	$I_o = 5\text{mA}$		-0.8		mV/ $^\circ\text{C}$
Output noise voltage	$V_N$	$f = 10\text{Hz}$ to $100\text{kHz}$ , $T_a = 25^\circ\text{C}$		42		$\mu\text{V}$
Ripple rejection	RR	$f = 120\text{Hz}$ , $V_i = 8\text{V}$ to $18\text{V}$	62	73		dB
Dropout voltage	$V_o$	$I_o = 1.0\text{A}$ , $T_j = 25^\circ\text{C}$		2		V
Output resistance	$R_o$	$f = 1\text{kHz}$		15		$\text{m}\Omega$
Short circuit current	$I_{sc}$	$V_i = 35\text{V}$ , $T_a = 25^\circ\text{C}$		230		mA
peak current	$I_{pk}$	$T_j = 25^\circ\text{C}$		2.2		A

**UTC7806 ELECTRICAL CHARACTERISTICS**(Refer to test circuits,  $0 < T_j < 125^\circ\text{C}$ ,  $I_o = 500\text{mA}$ ,  $V_i = 11\text{V}$ ,  $C_i = 0.33\mu\text{F}$ ,  $C_o = 0.1\mu\text{F}$ , unless otherwise specified)

Characteristic	Symbol	Test Conditions	Min	Typ	Max	Units
Output voltage	$V_o$	$T_j = 25^\circ\text{C}$	5.75	6.00	6.25	V
		$5.0\text{mA} < I_o < 1.0\text{A}$ , $P_o < 15\text{W}$ $V_i = 8.5\text{V}$ to $21\text{V}$	5.7	6.0	6.3	V
Line regulation	$\Delta V_o$	$T_j = 25^\circ\text{C}$ , $V_i = 8.5\text{V}$ to $25\text{V}$		5	120	mV
		$T_j = 25^\circ\text{C}$ , $V_i = 9\text{V}$ to $13\text{V}$		1.5	60	mV
Load regulation	$\Delta V_o$	$T_j = 25^\circ\text{C}$ , $I_o = 5.0\text{mA}$ to $1.5\text{A}$		9	130	mV
		$T_j = 25^\circ\text{C}$ , $I_o = 250\text{mA}$ to $750\text{mA}$		3	60	mV
Quiescent current	$I_Q$	$T_j = 25^\circ\text{C}$		5.0	8	mA
Quiescent current change	$\Delta I_Q$	$I_o = 5\text{mA}$ to $1.0\text{A}$			0.5	mA
		$V_i = 9\text{V}$ to $25\text{V}$			0.8	mA
Output voltage drift	$\Delta V_o / \Delta T$	$I_o = 5\text{mA}$		-0.8		mV/ $^\circ\text{C}$
Output noise voltage	$V_N$	$f = 10\text{Hz}$ to $100\text{kHz}$ , $T_a = 25^\circ\text{C}$		45		$\mu\text{V}$
Ripple rejection	RR	$f = 120\text{Hz}$ , $V_i = 9\text{V}$ to $19\text{V}$	59	75		dB
Dropout voltage	$V_o$	$I_o = 1.0\text{A}$ , $T_j = 25^\circ\text{C}$		2		V
Output resistance	$R_o$	$f = 1\text{kHz}$		19		$\text{m}\Omega$
Short circuit current	$I_{sc}$	$V_i = 35\text{V}$ , $T_a = 25^\circ\text{C}$		250		mA
peak current	$I_{pk}$	$T_j = 25^\circ\text{C}$		2.2		A

**UTC7808 ELECTRICAL CHARACTERISTICS**(Refer to test circuits,  $0 < T_j < 125^\circ\text{C}$ ,  $I_o = 500\text{mA}$ ,  $V_i = 14\text{V}$ ,  $C_i = 0.33\mu\text{F}$ ,  $C_o = 0.1\mu\text{F}$ , unless otherwise specified)

Characteristic	Symbol	Test Conditions	Min	Typ	Max	Units
Output voltage	$V_o$	$T_j = 25^\circ\text{C}$	7.7	8.0	8.3	V
		$5.0\text{mA} < I_o < 1.0\text{A}$ , $P_o < 15\text{W}$ $V_i = 11\text{V}$ to $23\text{V}$	7.6	8.0	8.4	V
Line regulation	$\Delta V_o$	$T_j = 25^\circ\text{C}$ , $V_i = 10.5\text{V}$ to $25\text{V}$		5.0	160	mV
		$T_j = 25^\circ\text{C}$ , $V_i = 11\text{V}$ to $17\text{V}$		2.0	80	mV
Load regulation	$\Delta V_o$	$T_j = 25^\circ\text{C}$ , $I_o = 5.0\text{mA}$ to $1.5\text{A}$		10	160	mV
		$T_j = 25^\circ\text{C}$ , $I_o = 250\text{mA}$ to $750\text{mA}$		5.0	80	mV
Quiescent current	$I_Q$	$T_j = 25^\circ\text{C}$		5.0	8	mA
Quiescent current change	$\Delta I_Q$	$I_o = 5\text{mA}$ to $1.0\text{A}$		0.05	0.5	mA
		$V_i = 11\text{V}$ to $25\text{V}$		0.5	1.0	mA
Output voltage drift	$\Delta V_o / \Delta T$	$I_o = 5\text{mA}$		-0.8		mV/ $^\circ\text{C}$
Output noise voltage	$V_N$	$f = 10\text{Hz}$ to $100\text{kHz}$ , $T_a = 25^\circ\text{C}$		52		$\mu\text{V}$
Ripple rejection	RR	$f = 120\text{Hz}$ , $V_i = 11.5\text{V}$ to $21.5\text{V}$	56	73		dB
Dropout voltage	$V_o$	$I_o = 1.0\text{A}$ , $T_j = 25^\circ\text{C}$		2		V
Output resistance	$R_o$	$f = 1\text{kHz}$		17		$\text{m}\Omega$
Short circuit current	$I_{sc}$	$V_i = 35\text{V}$ , $T_a = 25^\circ\text{C}$		230		mA
peak current	$I_{pk}$	$T_j = 25^\circ\text{C}$		2.2		A

**UTC7809 ELECTRICAL CHARACTERISTICS**(Refer to test circuits,  $0 < T_j < 125^\circ\text{C}$ ,  $I_o = 500\text{mA}$ ,  $V_i = 15\text{V}$ ,  $C_i = 0.33\mu\text{F}$ ,  $C_o = 0.1\mu\text{F}$ , unless otherwise specified)

Characteristic	Symbol	Test Conditions	Min	Typ	Max	Units
Output voltage	$V_o$	$T_j = 25^\circ\text{C}$	8.65	9.00	9.35	V
		$5.0\text{mA} < I_o < 1.0\text{A}$ , $P_o < 15\text{W}$ $V_i = 11.5\text{V}$ to $24\text{V}$	8.6	9.0	9.4	V
Line regulation	$\Delta V_o$	$T_j = 25^\circ\text{C}$ , $V_i = 11.5\text{V}$ to $25\text{V}$		6	180	mV
		$T_j = 25^\circ\text{C}$ , $V_i = 12\text{V}$ to $25\text{V}$		2	90	mV
Load regulation	$\Delta V_o$	$T_j = 25^\circ\text{C}$ , $I_o = 5.0\text{mA}$ to $1.5\text{A}$		12	180	mV
		$T_j = 25^\circ\text{C}$ , $I_o = 250\text{mA}$ to $750\text{mA}$		4	90	mV
Quiescent current	$I_Q$	$T_j = 25^\circ\text{C}$		5.0	8	mA
Quiescent current change	$\Delta I_Q$	$I_o = 5\text{mA}$ to $1.0\text{A}$			0.5	mA
		$V_i = 12\text{V}$ to $26\text{V}$			0.8	mA
Output voltage drift	$\Delta V_o / \Delta T$	$I_o = 5\text{mA}$		-1		mV/ $^\circ\text{C}$
Output noise voltage	$V_N$	$f = 10\text{Hz}$ to $100\text{kHz}$ , $T_a = 25^\circ\text{C}$		58		$\mu\text{V}$
Ripple rejection	RR	$f = 120\text{Hz}$ , $V_i = 13\text{V}$ to $23\text{V}$	56	71		dB
Dropout voltage	$V_o$	$I_o = 1.0\text{A}$ , $T_j = 25^\circ\text{C}$		2		V
Output resistance	$R_o$	$f = 1\text{kHz}$		15		$\text{m}\Omega$
Short circuit current	$I_{sc}$	$V_i = 35\text{V}$ , $T_a = 25^\circ\text{C}$		250		mA
peak current	$I_{pk}$	$T_j = 25^\circ\text{C}$		2.2		A

**UTC7810 ELECTRICAL CHARACTERISTICS**(Refer to test circuits,  $0 < T_j < 125^\circ\text{C}$ ,  $I_o = 500\text{mA}$ ,  $V_i = 16\text{V}$ ,  $C_i = 0.33\mu\text{F}$ ,  $C_o = 0.1\mu\text{F}$ , unless otherwise specified)

Characteristic	Symbol	Test Conditions	Min	Typ	Max	Units
Output voltage	$V_o$	$T_j = 25^\circ\text{C}$	9.6	10	10.4	V
		$5.0\text{mA} < I_o < 1.0\text{A}$ , $P_o < 15\text{W}$ $V_i = 12.5\text{V}$ to $25\text{V}$	9.5	10	10.5	V
Line regulation	$\Delta V_o$	$T_j = 25^\circ\text{C}$ , $V_i = 12.5\text{V}$ to $25\text{V}$		10	200	mV
		$T_j = 25^\circ\text{C}$ , $V_i = 13\text{V}$ to $20\text{V}$		3	100	mV
Load regulation	$\Delta V_o$	$T_j = 25^\circ\text{C}$ , $I_o = 5.0\text{mA}$ to $1.5\text{A}$		12	200	mV
		$T_j = 25^\circ\text{C}$ , $I_o = 250\text{mA}$ to $750\text{mA}$		4	100	mV
Quiescent current	$I_Q$	$T_j = 25^\circ\text{C}$		5.0	8	mA
Quiescent current change	$\Delta I_Q$	$I_o = 5\text{mA}$ to $1.0\text{A}$			0.5	mA
		$V_i = 13\text{V}$ to $29\text{V}$			0.8	mA
Output voltage drift	$\Delta V_o / \Delta T$	$I_o = 5\text{mA}$		-1		mV/ $^\circ\text{C}$
Output noise voltage	$V_N$	$f = 10\text{Hz}$ to $100\text{kHz}$ , $T_a = 25^\circ\text{C}$		58		$\mu\text{V}$
Ripple rejection	RR	$f = 120\text{Hz}$ , $V_i = 14\text{V}$ to $24\text{V}$	56	71		dB
Dropout voltage	$V_o$	$I_o = 1.0\text{A}$ , $T_j = 25^\circ\text{C}$		2		V
Output resistance	$R_o$	$f = 1\text{kHz}$		17		$\text{m}\Omega$
Short circuit current	$I_{sc}$	$V_i = 35\text{V}$ , $T_a = 25^\circ\text{C}$		250		mA
peak current	$I_{pk}$	$T_j = 25^\circ\text{C}$		2.2		A

**UTC7812 ELECTRICAL CHARACTERISTICS**(Refer to test circuits,  $0 < T_j < 125^\circ\text{C}$ ,  $I_o = 500\text{mA}$ ,  $V_i = 16\text{V}$ ,  $C_i = 0.33\mu\text{F}$ ,  $C_o = 0.1\mu\text{F}$ , unless otherwise specified)

Characteristic	Symbol	Test Conditions	Min	Typ	Max	Units
Output voltage	$V_o$	$T_j = 25^\circ\text{C}$	11.5	12.0	12.5	V
		$5.0\text{mA} < I_o < 1.0\text{A}$ , $P_o < 15\text{W}$ $V_i = 14.5\text{V}$ to $27\text{V}$	11.4	12	12.6	V
Line regulation	$\Delta V_o$	$T_j = 25^\circ\text{C}$ , $V_i = 14.5\text{V}$ to $30\text{V}$		10	240	mV
		$T_j = 25^\circ\text{C}$ , $V_i = 16\text{V}$ to $22\text{V}$		3	120	mV
Load regulation	$\Delta V_o$	$T_j = 25^\circ\text{C}$ , $I_o = 5.0\text{mA}$ to $1.5\text{A}$		11	240	mV
		$T_j = 25^\circ\text{C}$ , $I_o = 250\text{mA}$ to $750\text{mA}$		5.0	120	mV
Quiescent current	$I_Q$	$T_j = 25^\circ\text{C}$		5.1	8	mA
Quiescent current change	$\Delta I_Q$	$I_o = 5\text{mA}$ to $1.0\text{A}$			0.5	mA
		$V_i = 15\text{V}$ to $30\text{V}$			0.8	mA
Output voltage drift	$\Delta V_o / \Delta T$	$I_o = 5\text{mA}$		-1		mV/ $^\circ\text{C}$
Output noise voltage	$V_N$	$f = 10\text{Hz}$ to $100\text{kHz}$ , $T_a = 25^\circ\text{C}$		76		$\mu\text{V}$
Ripple rejection	RR	$f = 120\text{Hz}$ , $V_i = 15\text{V}$ to $25\text{V}$	55	71		dB
Dropout voltage	$V_o$	$I_o = 1.0\text{A}$ , $T_j = 25^\circ\text{C}$		2		V
Output resistance	$R_o$	$f = 1\text{kHz}$		18		$\text{m}\Omega$
Short circuit current	$I_{sc}$	$V_i = 35\text{V}$ , $T_a = 25^\circ\text{C}$		230		mA
peak current	$I_{pk}$	$T_j = 25^\circ\text{C}$		2.2		A

**UTC7815 ELECTRICAL CHARACTERISTICS**(Refer to test circuits,  $0 < T_j < 125^\circ\text{C}$ ,  $I_o = 500\text{mA}$ ,  $V_i = 23\text{V}$ ,  $C_i = 0.33\mu\text{F}$ ,  $C_o = 0.1\mu\text{F}$ , unless otherwise specified)

Characteristic	Symbol	Test Conditions	Min	Typ	Max	Units
Output voltage	$V_o$	$T_j = 25^\circ\text{C}$	14.4	15.0	15.6	V
		$5.0\text{mA} < I_o < 1.0\text{A}$ , $P_o < 15\text{W}$ $V_i = 17.5\text{V}$ to $30\text{V}$	14.25	15	15.75	V
Line regulation	$\Delta V_o$	$T_j = 25^\circ\text{C}$ , $V_i = 17.5\text{V}$ to $30\text{V}$		11	300	mV
		$T_j = 25^\circ\text{C}$ , $V_i = 20\text{V}$ to $26\text{V}$		3	150	mV
Load regulation	$\Delta V_o$	$T_j = 25^\circ\text{C}$ , $I_o = 5.0\text{mA}$ to $1.5\text{A}$		12	300	mV
		$T_j = 25^\circ\text{C}$ , $I_o = 250\text{mA}$ to $750\text{mA}$		4	150	mV
Quiescent current	$I_Q$	$T_j = 25^\circ\text{C}$		5.2	8	mA
Quiescent current change	$\Delta I_Q$	$I_o = 5\text{mA}$ to $1.0\text{A}$			0.5	mA
		$V_i = 18\text{V}$ to $305\text{V}$			0.8	mA
Output voltage drift	$\Delta V_o / \Delta T$	$I_o = 5\text{mA}$		-1		mV/ $^\circ\text{C}$
Output noise voltage	$V_N$	$f = 10\text{Hz}$ to $100\text{kHz}$ , $T_a = 25^\circ\text{C}$		90		$\mu\text{V}$
Ripple rejection	RR	$f = 120\text{Hz}$ , $V_i = 18.5\text{V}$ to $28.5\text{V}$	54	70		dB
Dropout voltage	$V_o$	$I_o = 1.0\text{A}$ , $T_j = 25^\circ\text{C}$		2		V
Output resistance	$R_o$	$f = 1\text{kHz}$		19		$\text{m}\Omega$
Short circuit current	$I_{sc}$	$V_i = 35\text{V}$ , $T_a = 25^\circ\text{C}$		250		mA
peak current	$I_{pk}$	$T_j = 25^\circ\text{C}$		2.2		A

**UTC7818 ELECTRICAL CHARACTERISTICS**(Refer to test circuits,  $0 < T_j < 125^\circ\text{C}$ ,  $I_o = 500\text{mA}$ ,  $V_i = 23\text{V}$ ,  $C_i = 0.33\mu\text{F}$ ,  $C_o = 0.1\mu\text{F}$ , unless otherwise specified)

Characteristic	Symbol	Test Conditions	Min	Typ	Max	Units
Output voltage	$V_o$	$T_j = 25^\circ\text{C}$	17.3	18.0	18.7	V
		$5.0\text{mA} < I_o < 1.0\text{A}$ , $P_o < 15\text{W}$ $V_i = 21\text{V}$ to $33\text{V}$	17.1	18	18.9	V
Line regulation	$\Delta V_o$	$T_j = 25^\circ\text{C}$ , $V_i = 21\text{V}$ to $33\text{V}$		15	360	mV
		$T_j = 25^\circ\text{C}$ , $V_i = 24\text{V}$ to $30\text{V}$		5	180	mV
Load regulation	$\Delta V_o$	$T_j = 25^\circ\text{C}$ , $I_o = 5.0\text{mA}$ to $1.5\text{A}$		15	360	mV
		$T_j = 25^\circ\text{C}$ , $I_o = 250\text{mA}$ to $750\text{mA}$		5.0	180	mV
Quiescent current	$I_Q$	$T_j = 25^\circ\text{C}$		5.2	8	mA
Quiescent current change	$\Delta I_Q$	$I_o = 5\text{mA}$ to $1.0\text{A}$			0.5	mA
		$V_i = 21\text{V}$ to $32\text{V}$			0.8	mA
Output voltage drift	$\Delta V_o / \Delta T$	$I_o = 5\text{mA}$		-1		mV/ $^\circ\text{C}$
Output noise voltage	$V_N$	$f = 10\text{Hz}$ to $100\text{kHz}$ , $T_a = 25^\circ\text{C}$		110		$\mu\text{V}$
Ripple rejection	RR	$f = 120\text{Hz}$ , $V_i = 22\text{V}$ to $32\text{V}$	53	69		dB
Dropout voltage	$V_o$	$I_o = 1.0\text{A}$ , $T_j = 25^\circ\text{C}$		2		V
Output resistance	$R_o$	$f = 1\text{kHz}$		22		$\text{m}\Omega$
Short circuit current	$I_{sc}$	$V_i = 35\text{V}$ , $T_a = 25^\circ\text{C}$		250		mA
peak current	$I_{pk}$	$T_j = 25^\circ\text{C}$		2.2		A

## UTC7824 ELECTRICAL CHARACTERISTICS

(Refer to test circuits,  $0 < T_j < 125^\circ\text{C}$ ,  $I_o = 500\text{mA}$ ,  $V_i = 33\text{V}$ ,  $C_i = 0.33\mu\text{F}$ ,  $C_o = 0.1\mu\text{F}$ , unless otherwise specified)

Characteristic	Symbol	Test Conditions	Min	Typ	Max	Units
Output voltage	$V_o$	$T_j = 25^\circ\text{C}$	23	24	25	V
		$5.0\text{mA} < I_o < 1.0\text{A}$ , $P_o < 15\text{W}$ $V_i = 27\text{V}$ to $38\text{V}$	22.8	24	25.2	V
Line regulation	$\Delta V_o$	$T_j = 25^\circ\text{C}$ , $V_i = 27\text{V}$ to $38\text{V}$		17	480	mV
		$T_j = 25^\circ\text{C}$ , $V_i = 30\text{V}$ to $36\text{V}$		6	240	mV
Load regulation	$\Delta V_o$	$T_j = 25^\circ\text{C}$ , $I_o = 5.0\text{mA}$ to $1.5\text{A}$		15	480	mV
		$T_j = 25^\circ\text{C}$ , $I_o = 250\text{mA}$ to $750\text{mA}$		5.0	240	mV
Quiescent current	$I_Q$	$T_j = 25^\circ\text{C}$		5.2	8	mA
Quiescent current change	$\Delta I_Q$	$I_o = 5\text{mA}$ to $1.0\text{A}$			0.5	mA
		$V_i = 27\text{V}$ to $38\text{V}$			0.8	mA
Output voltage drift	$\Delta V_o / \Delta T$	$I_o = 5\text{mA}$		-1.5		mV/ $^\circ\text{C}$
Output noise voltage	$V_N$	$f = 10\text{Hz}$ to $100\text{kHz}$ , $T_a = 25^\circ\text{C}$		160		$\mu\text{V}$
Ripple rejection	RR	$f = 120\text{Hz}$ , $V_i = 28\text{V}$ to $38\text{V}$	50	67		dB
Dropout voltage	$V_o$	$I_o = 1.0\text{A}$ , $T_j = 25^\circ\text{C}$		2		V
Output resistance	$R_o$	$f = 1\text{kHz}$		28		$\text{m}\Omega$
Short circuit current	$I_{sc}$	$V_i = 35\text{V}$ , $T_a = 25^\circ\text{C}$		230		mA
peak current	$I_{pk}$	$T_j = 25^\circ\text{C}$		2.2		A

## TEST CIRCUITS

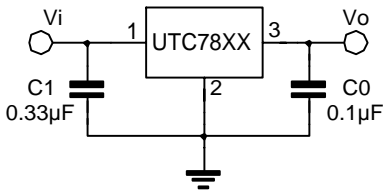

FIG.1 DC PARAMETERS

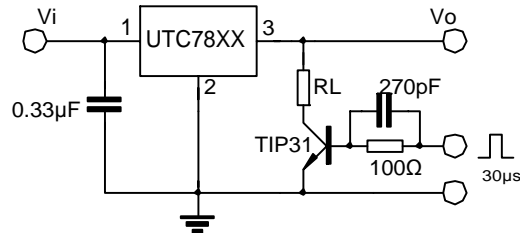

FIG.2 LOAD REGULATION

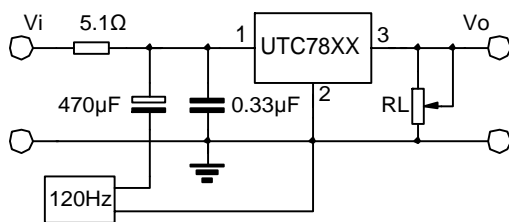

FIG.3 RIPPLE REJECTION

## APPLICATION CIRCUITS

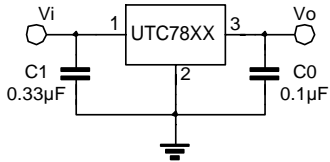

Fig.4 Fixed output regulator

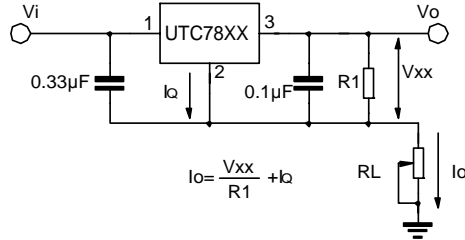

Fig.5 Constant current regulator

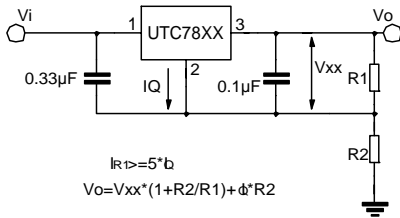

Fig.6 Circuit for increasing Regulator output voltage

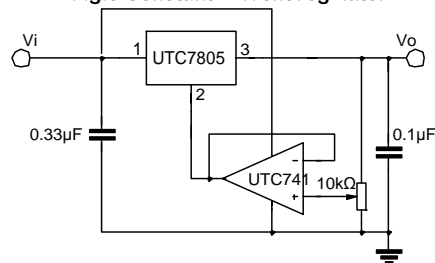

Fig.7 Adjustable output

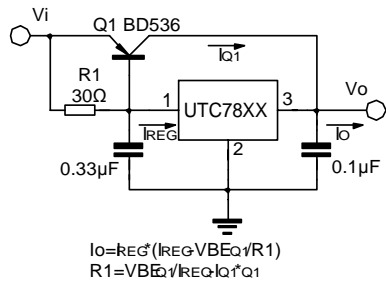

Fig.8 High current with voltage regulator

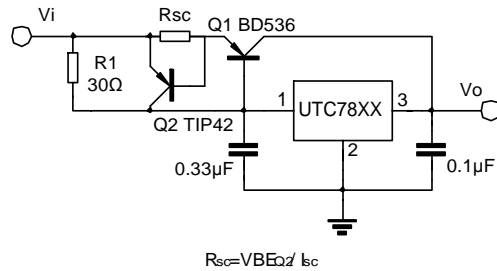

Fig.9 High output current short circuit protection

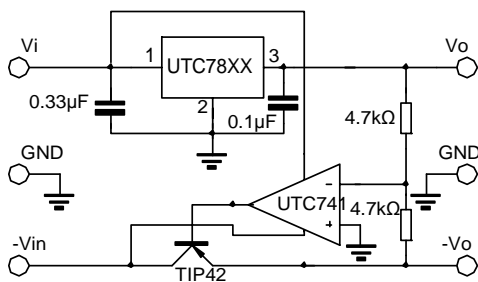

Fig.10 Tracking voltage regulator

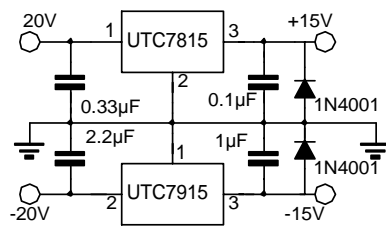

Fig.11 Split power supply(±15V,1A)

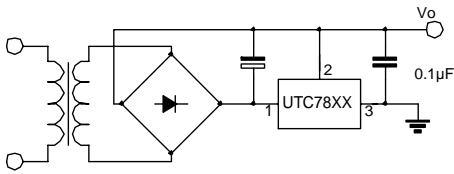

Fig.12 Negative output voltage circuit

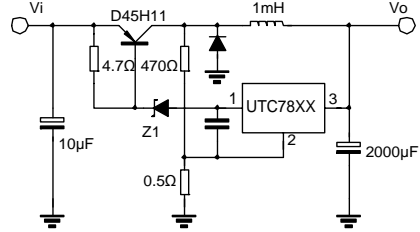

Fig.13 switching regulator

TYPICAL PERFORMANCE CHARACTERISTICS

Fig.14 Quiescent current

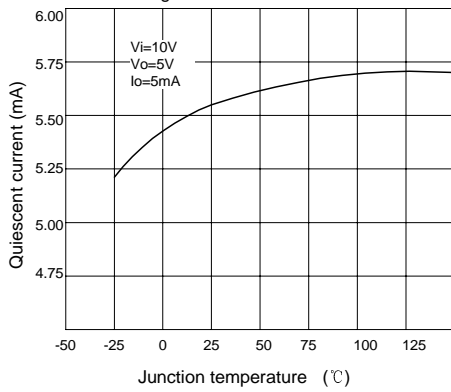

Fig.15 Output voltage

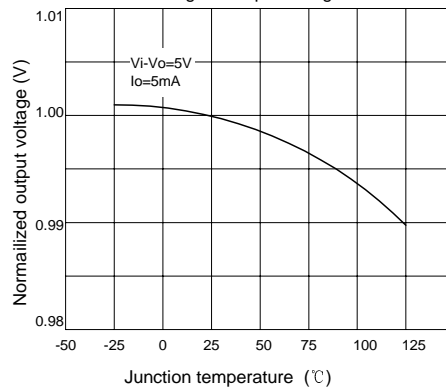

Fig.16 Peak output current

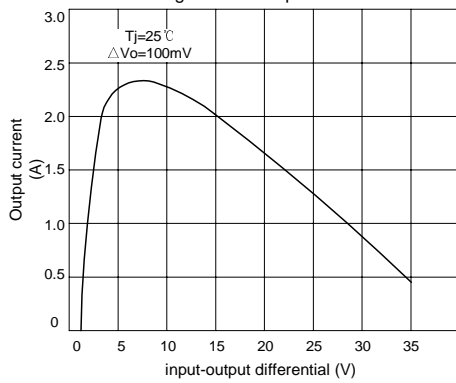
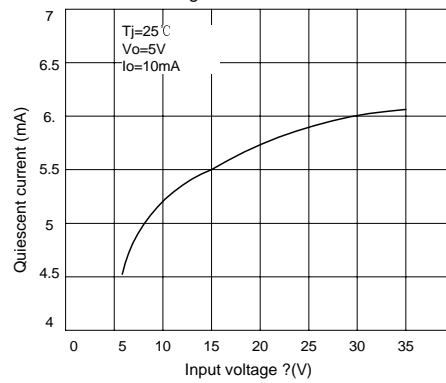
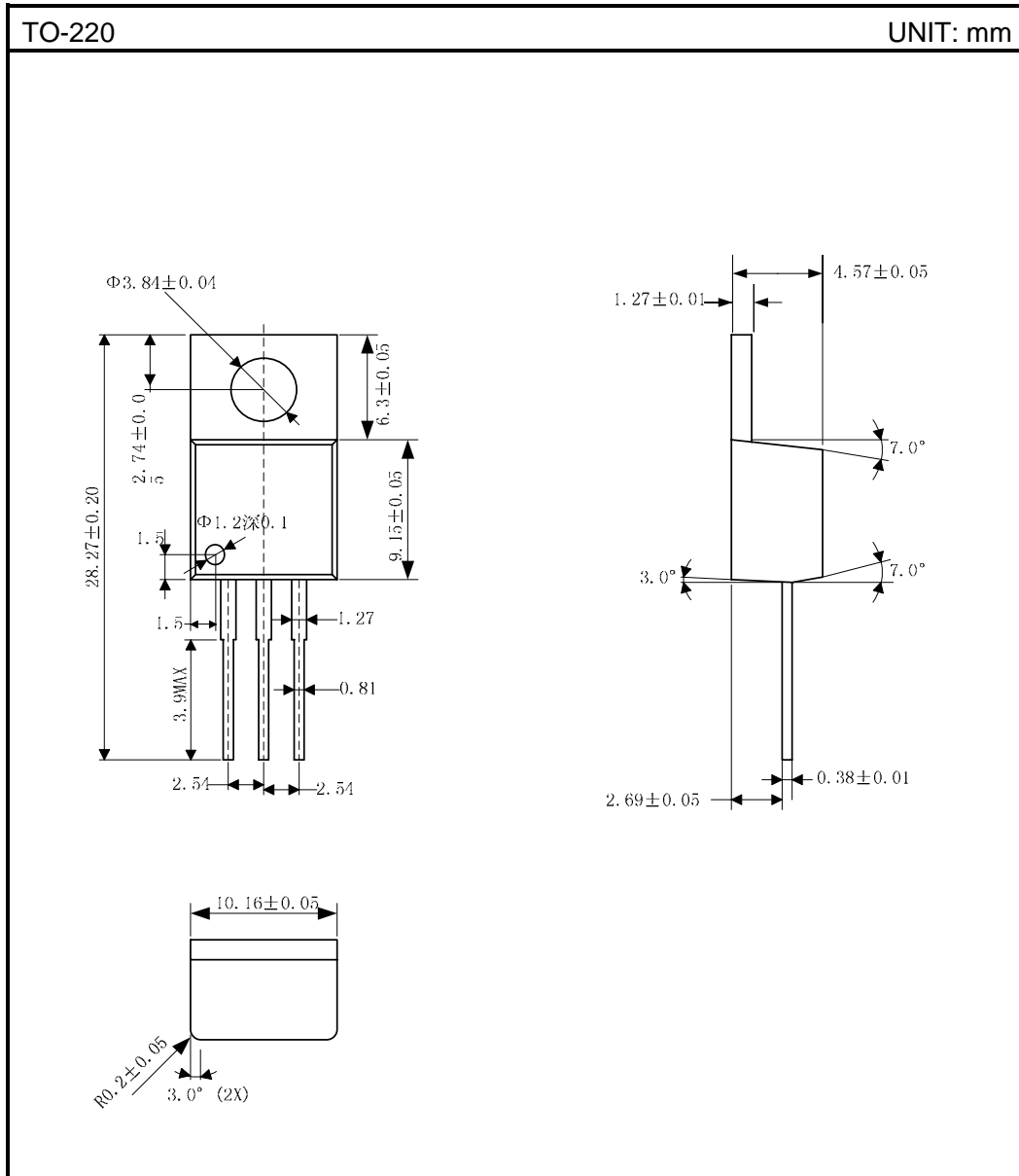

Fig.17 Quiescent current





PACKAGE OUTLINE



Attach

Revision History

Data	REV	Description	Page
	1.0	Original	
2005.03.30	1.1	Revise "BLOCK DIAGRAM"	1
2005.06.30	1.2	Revise "3-Dimension Outline " Add" Packge Outline TO-220"	1 9