

**DUAL OPERATIONAL AMPLIFIERS**

**DESCRIPTION**

The UTC358 consists of dual independent, high gain internally frequency compensated operational amplifiers which were designed specifically to operate from a single power supply over a wide voltage range.

Operation from split power supplies is also possible so long as the difference between the two supplies is 3 volts to 32 volts.

Application areas include transducer amplifier, DC gain blocks and all the conventional OP amp circuits which now can be easily implemented in single power supply system.

**FEATURES**

- \*Internally frequency compensated for unity gain
- \*Large DC voltage gain :100dB
- \*Wide operating supply range( $V_{cc}=3V\sim 32V$ )
- \*Input common-mode voltage includes ground
- \*Large output voltage swing:From 0V to  $V_{cc}-1.5V$
- \*Power drain suitable for battery operation

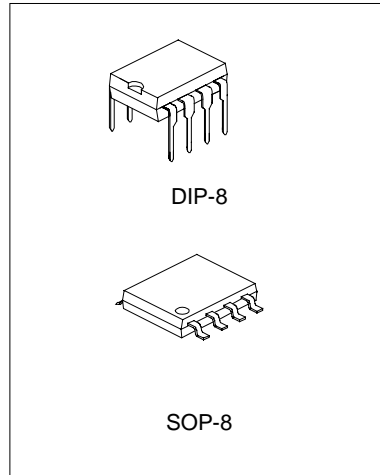

**BLOCK DIAGRAM**

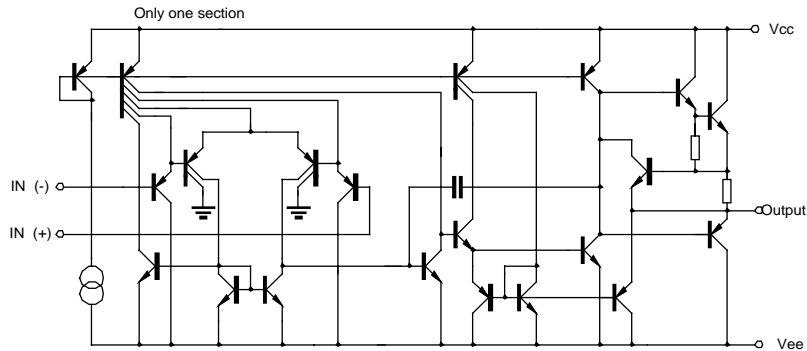

**ABSOLUTE MAXIMUM RATINGS**( $T_a=25^{\circ}C$ )

Characteristic	Symbol	Value	Unit
Supply Voltage	$V_{cc}$	$\pm 18$	V
Differential input voltage	$V_i(DIFF)$	32	V
Input Voltage	$V_i$	-0.3~32V	V
Power Dissipation	$P_d$	570	mW
Operating Temperature	$T_{opr}$	0 to +70	$^{\circ}C$
Storage Temperature	$T_{stg}$	-65 to 150	$^{\circ}C$

**ELECTRICAL CHARACTERISTICS**( Ta=25°C )

(Vcc=5.0V,All voltage referenced to GND unless otherwise specified)

Characteristic	Symbol	Test Condition	Min	Typ.	Max	Unit
Input offset voltage	V <sub>IO</sub>	V <sub>CM</sub> =0 to V <sub>CC</sub> -1.5 V <sub>O(p)</sub> =1.4V, R <sub>S</sub> =0		2.9	7.0	mV
Input offset current	I <sub>IO</sub>			5.0	50	nA
Input Bias current	I <sub>B</sub>			45	250	nA
Input Common-mode voltage range	V <sub>I(R)</sub>	V <sub>CC</sub> =30V	0	V <sub>CC</sub> -1.5		V
Supply Current	I <sub>CC</sub>	R <sub>L</sub> =∞, V <sub>CC</sub> =30V		0.8	2.0	mA
		V <sub>CC</sub> =5V		0.5	1.2	mA
Large signal Voltage Gain	G <sub>V</sub>	V <sub>CC</sub> =15V, R <sub>L</sub> >2kΩ V <sub>O(p)</sub> =1V to 11V	25	100		V/mV
Output voltage Swing	V <sub>(OH)</sub>	V <sub>CC</sub> =30V, R <sub>L</sub> =2kΩ	26			V
		V <sub>CC</sub> =30V, R <sub>L</sub> =10kΩ	27	28		V
	V <sub>(OL)</sub>	V <sub>CC</sub> =5, R <sub>L</sub> >10kΩ		5	20	mV
Common-mode rejection Ratio	CMRR		65	75		dB
Power supply rejection Ratio	PSRR		65	100		dB
Chanel Separation	CS	f=1kHz to 20kHz		5	20	mV
Short circuit to GND	I <sub>SC</sub>			40	60	mA
Output current	I <sub>source</sub>	V <sub>I(+)</sub> =1V, V <sub>I(-)</sub> =0 V <sub>CC</sub> =15V, V <sub>O(p)</sub> =2V	20	40		mA
	I <sub>sink</sub>	V <sub>I(+)</sub> =0V, V <sub>I(-)</sub> =1V V <sub>CC</sub> =15V, V <sub>O(p)</sub> =2V	10	13		mA
		V <sub>I(+)</sub> =1V, V <sub>I(-)</sub> =0 V <sub>CC</sub> =15V, V <sub>O(p)</sub> =200V	12	45		μA
Differential input voltage	V <sub>I(diff)</sub>				V <sub>CC</sub>	V

**PIN CONFIGURATION**

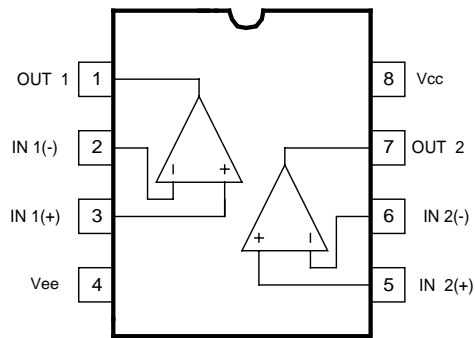

TYPICAL CHARACTERISTICS PERFORMANCE

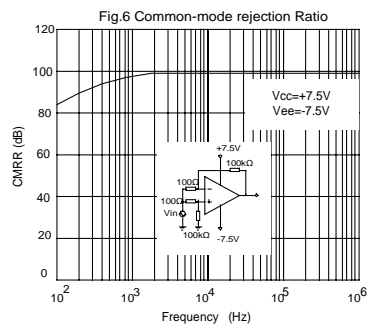
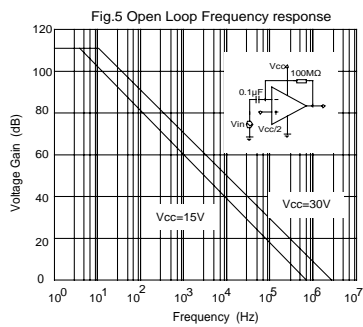
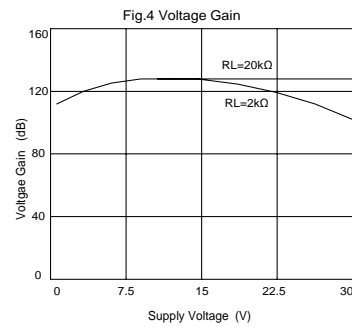
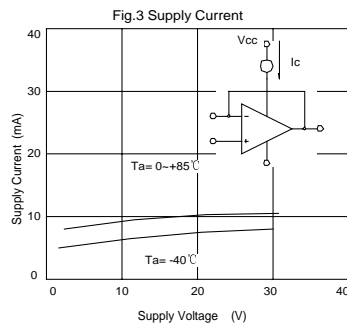
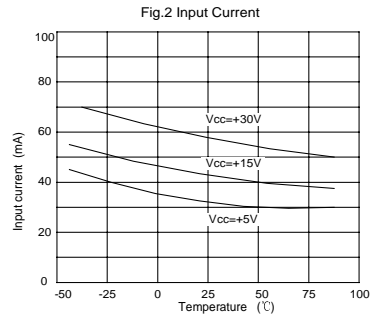
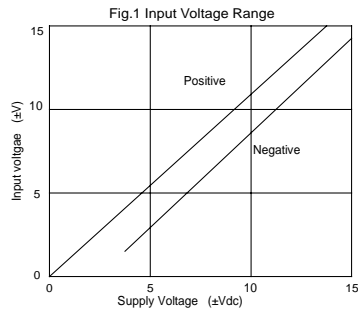

Fig.7

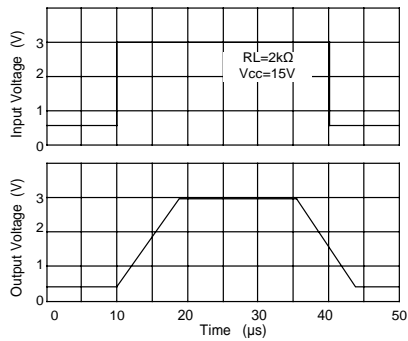

Fig.8 voltage Follower pulse response (small signal)

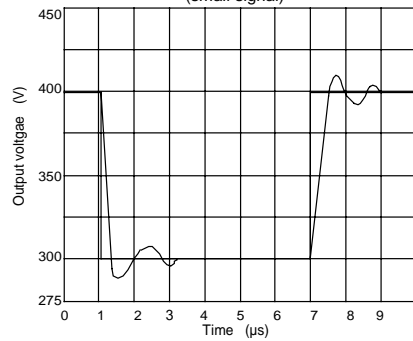

Fig.9 Large signal Frequency Response

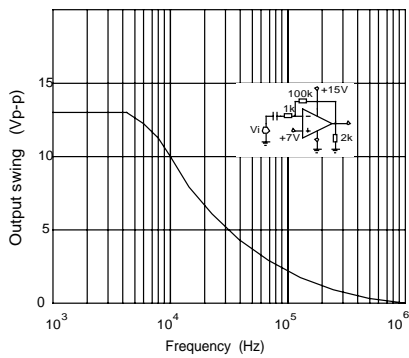

Fig.10 Output Characteristics current sourcing

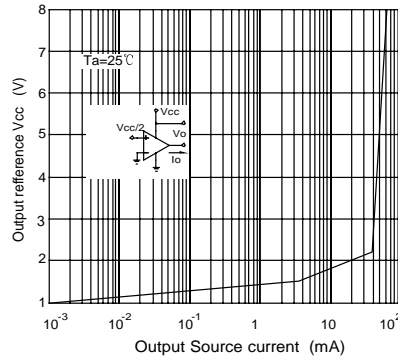

Fig.11 Output Characteristics Current sinking

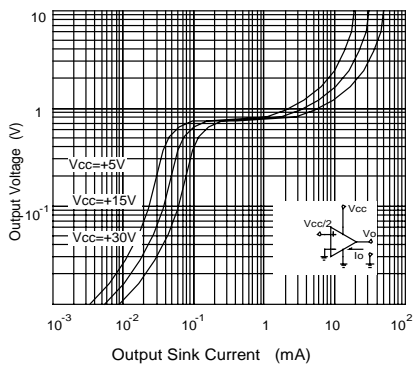
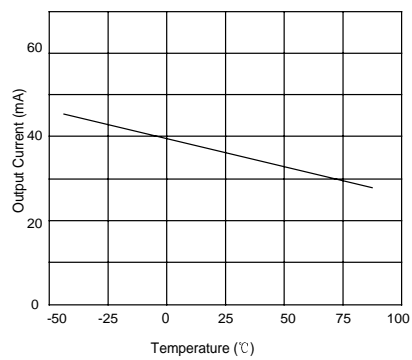

Fig.12 Current Limiting



PACKAGE OUTLINE

