

1A LDO VOLTAGE REGULATOR

DESCRIPTION

The SA1117C is a positive low voltage dropout regulator; voltage dropout is only 1.2V at 1A.

SA1117C provides two versions: fixed and adjustable versions. V_{OUT} has a tolerance of less than 1.5% for fixed versions 1.5V, 1.8V, 2.5V, 3.3V, 5.0V and adjustable version or 2% output accuracy for fixed version 1.2V.

The SA1117C offers some key features include thermal shutdown and current limiting. It is suitable for all electronic products.

FEATURES

- * 1.5% output accuracy for fixed versions 1.5V, 1.8V, 2.5V, 3.3V, 5.0V and adjustable version
- * 2% output accuracy for fixed version 1.2V
- * Low Dropout Voltage: 1.2V at 1A output current
- * Current Limiting
- * Thermal Shutdown
- * Temperature Range: -40°C to 125°C

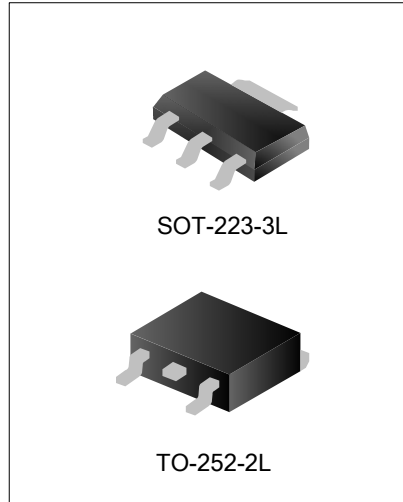

APPLICATIONS

- * Laptop, Palmtop, and Notebook Computers
- * Battery Charger
- * SCSI-II Active Terminator
- * Cellular Phone
- * Cordless Telephones
- * Battery Powered Systems
- * Portable Instrumentation
- * SMPS Post-Regulator

ORDERING INFORMATION (Temperature range: -40°C ~125°C)

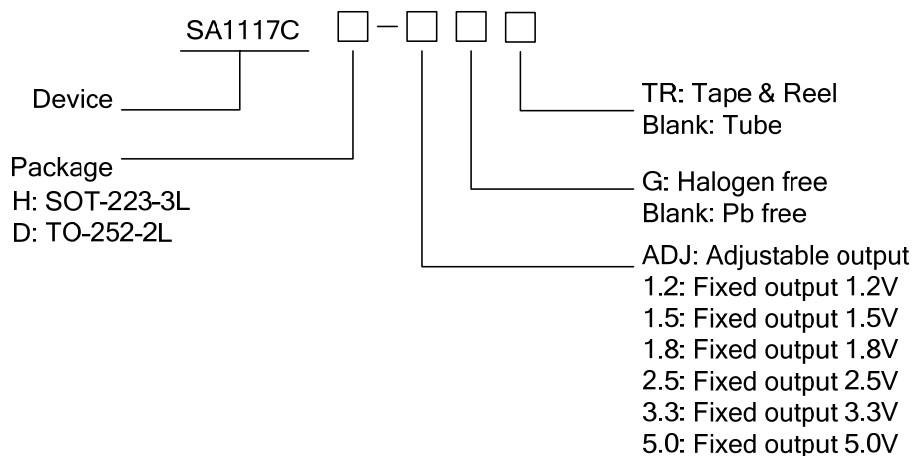

Part No.	Package	Marking	Material	Packing Type
SA1117CH-ADJTR	SOT-223-3L	SA1117CH-ADJ	Pb free	Tape & Reel
SA1117CH-1.2TR		SA1117CH-1.2	Pb free	Tape & Reel
SA1117CH-1.5TR		SA1117CH-1.5	Pb free	Tape & Reel
SA1117CH-1.8TR		SA1117CH-1.8	Pb free	Tape & Reel
SA1117CH-2.5TR		SA1117CH-2.5	Pb free	Tape & Reel
SA1117CH-3.3TR		SA1117CH-3.3	Pb free	Tape & Reel
SA1117CH-5.0TR		SA1117CH-5.0	Pb free	Tape & Reel
SA1117CD-ADJ	TO-252-2L	SA1117CD-ADJ	Pb free	Tube
SA1117CD-ADJTR		SA1117CD-ADJ	Pb free	Tape & Reel
SA1117CD-1.2		SA1117CD-1.2	Pb free	Tube
SA1117CD-1.2 TR		SA1117CD-1.2	Pb free	Tape & Reel
SA1117CD-1.5		SA1117CD-1.5	Pb free	Tube
SA1117CD-1.5TR		SA1117CD-1.5	Pb free	Tape & Reel
SA1117CD-1.8		SA1117CD-1.8	Pb free	Tube
SA1117CD-1.8TR		SA1117CD-1.8	Pb free	Tape & Reel
SA1117CD-2.5		SA1117CD-2.5	Pb free	Tube
SA1117CD-2.5TR		SA1117CD-2.5	Pb free	Tape & Reel
SA1117CD-3.3		SA1117CD-3.3	Pb free	Tube
SA1117CD-3.3TR		SA1117CD-3.3	Pb free	Tape & Reel
SA1117CD-5.0		SA1117CD-5.0	Pb free	Tube
SA1117CD-5.0TR		SA1117CD-5.0	Pb free	Tape & Reel

BLOCK DIAGRAM

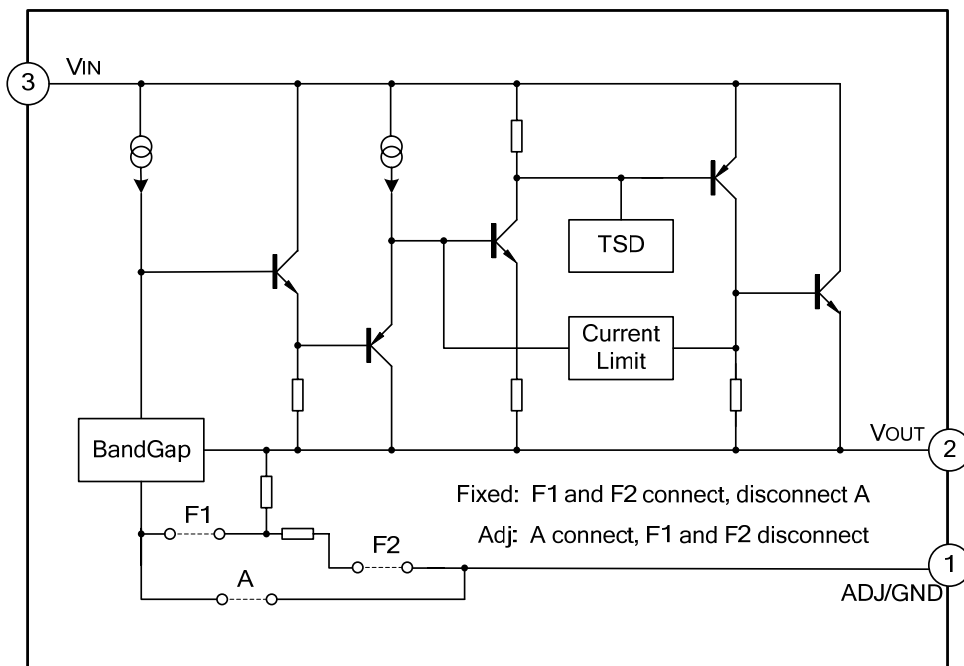

ABOSOLUTE MAXIMUM RATINGS

Characteristics	Symbol	Ratings	Unit
Input Supply Voltage	V _{IN}	15	V
Lead Temperature (Soldering, 5 seconds)	T _{Lead}	260	°C
Operating Junction Temperature Range	T _J	150	°C
Storage Temperature Range	T _{stg}	-65 ~ +150	V
Power Dissipation	P _D	Internally Limited (Note1)	mW
ESD Tolerance (Minimum)	ESD	2000	V

Note1: The maximum allowable power dissipation is a function of maximum operating junction temperature, T_J (max), the junction to ambient thermal resistance, θ_{JA}, and the ambient temperature T_{amb}. The maximum allowable power dissipation at any ambient temperature is given: P_D (max) = (T_J (max) - T_{amb})/θ_{JA}, exceeding the maximum allowable power limit will result in excessive die temperature; thus, the regulator will go into thermal shutdown. The junction to ambient thermal resistance, θ_{JA} of some packages may be different, The value of θ_{JA} depends on mounting technique.

RECOMMENDED OPERATING CONDITIONS

Characteristics	Symbol	Ratings	Unit
Input voltage	V _{IN}	12	V
Operating Junction Temperature Range	T _J	-40 ~ +125	°C

ELECTRICAL CHARACTERISTICS(T_{amb}=25°C, unless otherwise specified. Limits appearing in **Boldface** type apply over the entire junction temperature range for operation, -40°C to 125°C.)

Characteristics	Symbol	Conditions	Min.	Typ.	Max.	Unit
Reference Voltage	V _{REF}	SA1117C-ADJ, I _{OUT} =10mA, V _{IN} -V _{OUT} =2V, T _J =25°C 10mA ≤ I _{OUT} ≤ 1A, 1.4V ≤ V _{IN} -V _{OUT} ≤ 10V	1.231 1.225	1.250 1.250	1.268 1.275	V
		SA1117C-1.2, I _{OUT} =10mA, V _{IN} =3.2V, T _J =25°C 10mA ≤ I _{OUT} ≤ 1A, 3.0V ≤ V _{IN} ≤ 10V	1.176 1.152	1.2 1.2	1.224 1.248	V
Output Voltage	V _{OUT}	SA1117C-1.5, I _{OUT} =10mA, V _{IN} =3.5V, T _J =25°C 10mA ≤ I _{OUT} ≤ 1A, 3.0V ≤ V _{IN} ≤ 10V	1.477 1.470	1.500 1.500	1.522 1.530	V
		SA1117C-1.8, I _{OUT} =10mA, V _{IN} =3.8V, T _J =25°C, 0 ≤ I _{OUT} ≤ 1A, 3.2V ≤ V _{IN} ≤ 10V	1.773 1.746	1.800 1.800	1.827 1.854	V
		SA1117C -2.5, I _{OUT} =10mA, V _{IN} =4.5V, T _J =25°C, 0 ≤ I _{OUT} ≤ 1A, 3.9V ≤ V _{IN} ≤ 10V	2.462 2.450	2.500 2.500	2.538 2.550	V
		SA1117C-3.3, I _{OUT} =10mA, V _{IN} =5V, T _J =25°C, 0 ≤ I _{OUT} ≤ 1A, 4.75V ≤ V _{IN} ≤ 10V	3.250 3.235	3.300 3.300	3.349 3.365	V

Characteristics	Symbol	Conditions	Min.	Typ.	Max.	Unit
Output Voltage	V _{OUT}	SA1117C-5.0, I _{OUT} =10mA, V _{IN} =7V, T _J =25°C, 0 ≤ I _{OUT} ≤ 1A, 6.5V ≤ V _{IN} ≤ 12V	4.925 4.900	5.000 5.000	5.075 5.10	V
Output Voltage Temperature Stability	T _{SOUT}			0.3		%
Line Regulation	R _{line}	V _{INMIN} ≤ V _{IN} ≤ 12V, V _{OUT} =Fixed/Adj, I _{OUT} =10mA		6	15	mV
Load Regulation	R _{load}	10mA ≤ I _{OUT} ≤ 800mA, V _{OUT} =Fixed/Adj		6	18	mV
Dropout Voltage	V _{drop}	I _{OUT} =100mA I _{OUT} =500mA I _{OUT} =1A		1.00 1.05 1.20	1.20 1.25 1.30	V
Quiescent Current	I _q	4.25V ≤ V _{IN} ≤ 6.5V		5	10	mA
Ripple Rejection	P _{SRR}	f _{RIIPPLE} =120Hz, (V _{IN} -V _{OUT})=3V, V _{RIIPPLE} =1V _{PP}	50	60		dB
Adjust pin Current	I _{adj}			60	120	μA
Adjust pin Current Change		0 ≤ I _{OUT} ≤ 800mA, 1.4V ≤ V _{IN} -V _{OUT} ≤ 10V		0.2	5	μA
Thermal shutdown	T _{SD}			150		°C
Current limiting	I _{limit}		1.4	1.6	1.8	A
Temperature Stability				0.5		%
Long Term Stability		T _{AMB} =125°C, 1000Hrs		0.3		%
RMS Output Noise		% of V _{OUT} , 10Hz ≤ f ≤ 10kHz		0.005		%
Thermal Resistor Coefficient (No Heat-Sink)	θ _{JA}	SOT-223-3L		120		
		TO-252-2L		100		°C/W

PIN CONFIGURATION

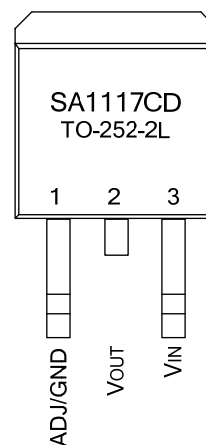
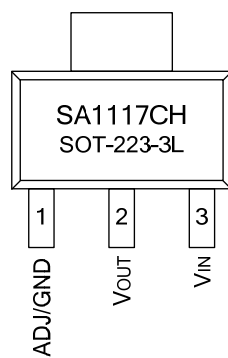

PIN DESCRIPTION

Pin No.	Pin name	I/O	Functions
1	GND/ADJ	--/O	Ground/ADJ
2	VOUT	O	Output voltage
3	VIN	I	Input supply voltage

FUNCTION DESCRIPTION

The SA1117C is a LDO regulator, its pass transistor is made up of a single NPN transistor being driven by a PNP. The dropout voltage is defined as: $V_{DROP} = V_{BE} + V_{SAT}$.

The SA1117C series of fixed and adjustable regulators are easy to use. Output voltages are 1.2V, 1.5V, 1.8V, 2.5V, 3.3V, and 5.0V. On-chip thermal shut down provides protection against any combination of overload and ambient temperature that would create excessive junction temperature.

The SA1117C requires an output capacitor for device stability. Its value of 22μF tantalum covers all cases of bypassing the adjustment terminal. Without bypassing the adjustment terminal smaller capacitors can be used with equally good results which depend upon the application circuit. In general, linear regulator stability decreases with higher output currents.

TYPICAL APPLICATION CIRCUIT

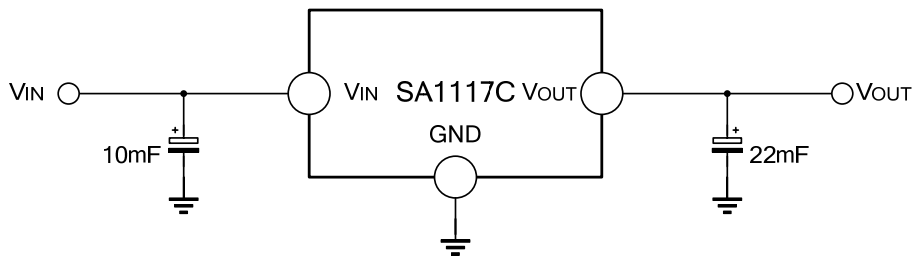

Figure 1. Typical Fixed Output Voltage

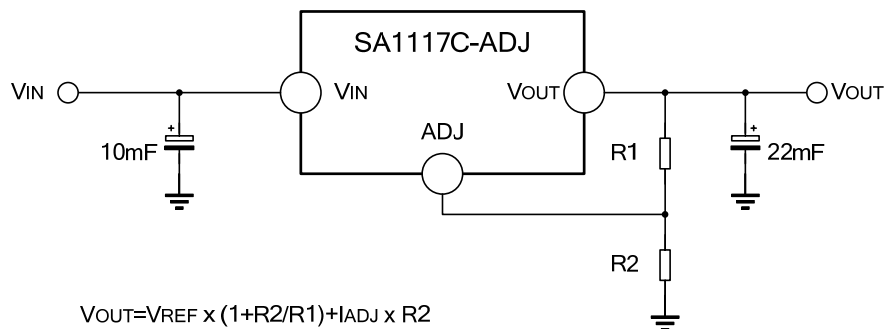
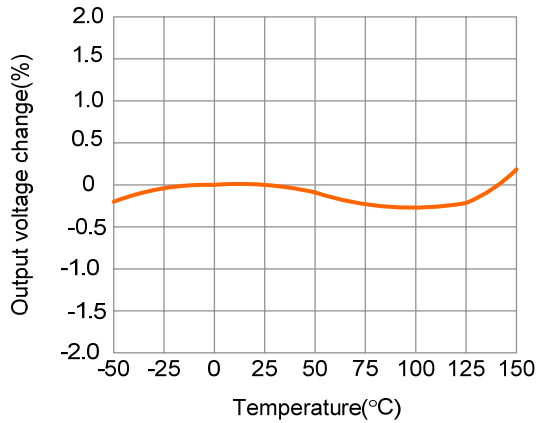

Figure 2. Typical Adjustable Output Voltage

Note: The circuit and parameters are reference only, please set the parameters of the real application circuit based on the real test.

TYPICAL CHARACTERISTICS CURVES

Temperature Stability



Adjust Pin Current

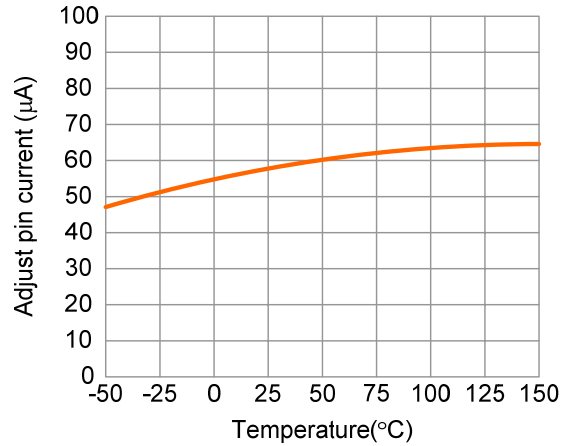

V_{OUT}=5 V Load Transient Response

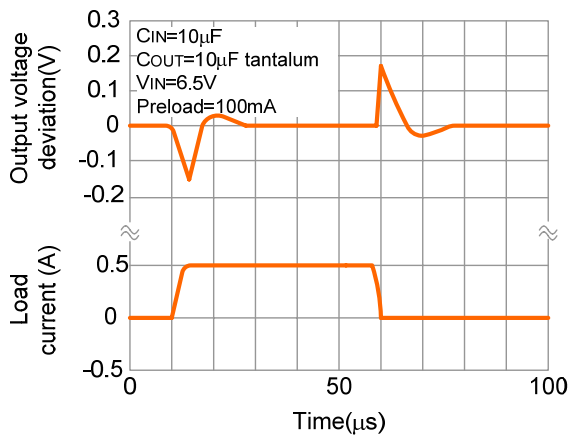

V_{OUT}=5 V Line Transient Response

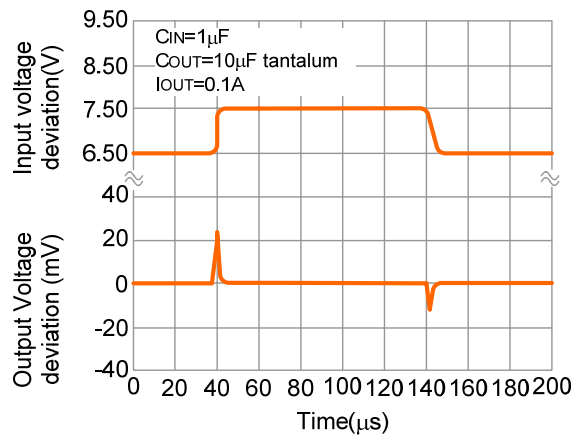

Ripple Rejection VS Current

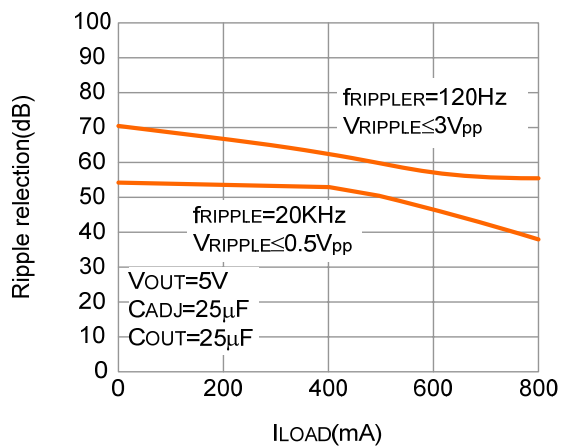

PACKAGE OUTLINE

TO-252-2L

Unit: mm

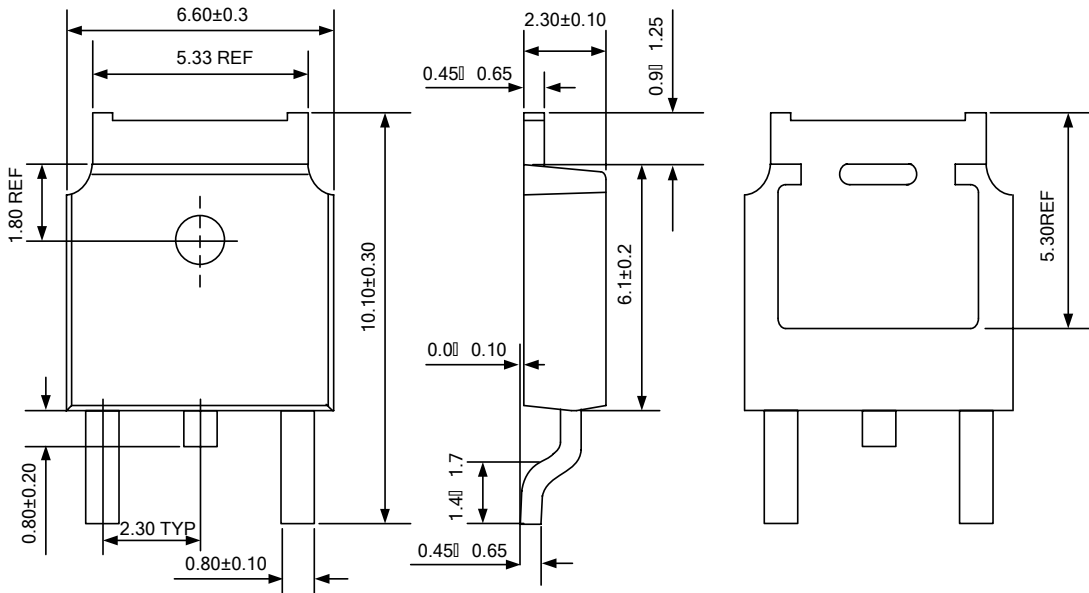

TO-252-2L

Unit: mm

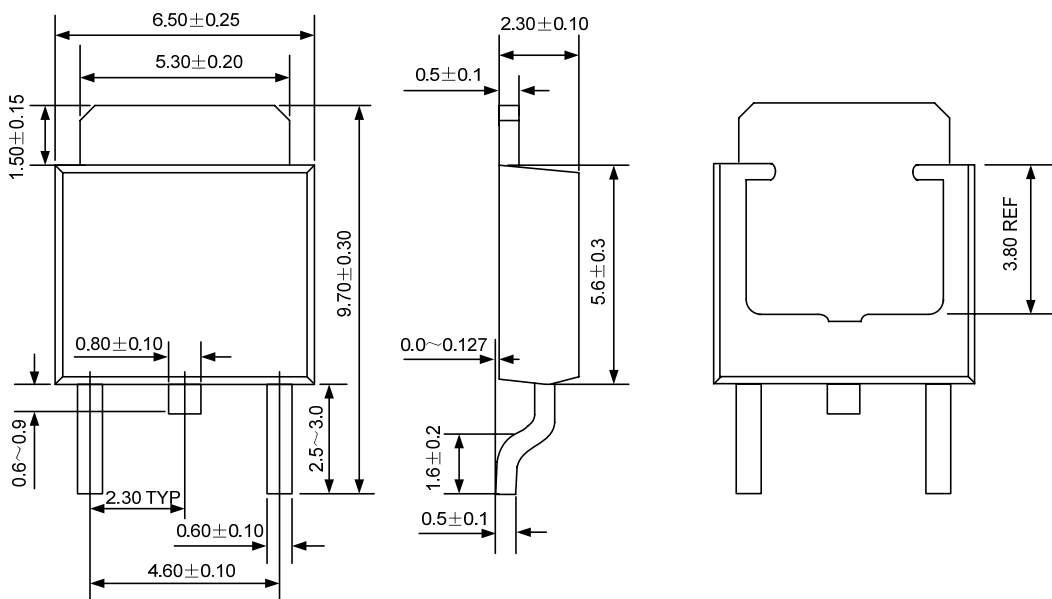

PACKAGE OUTLINE

SOT-223-3L

Unit: mm

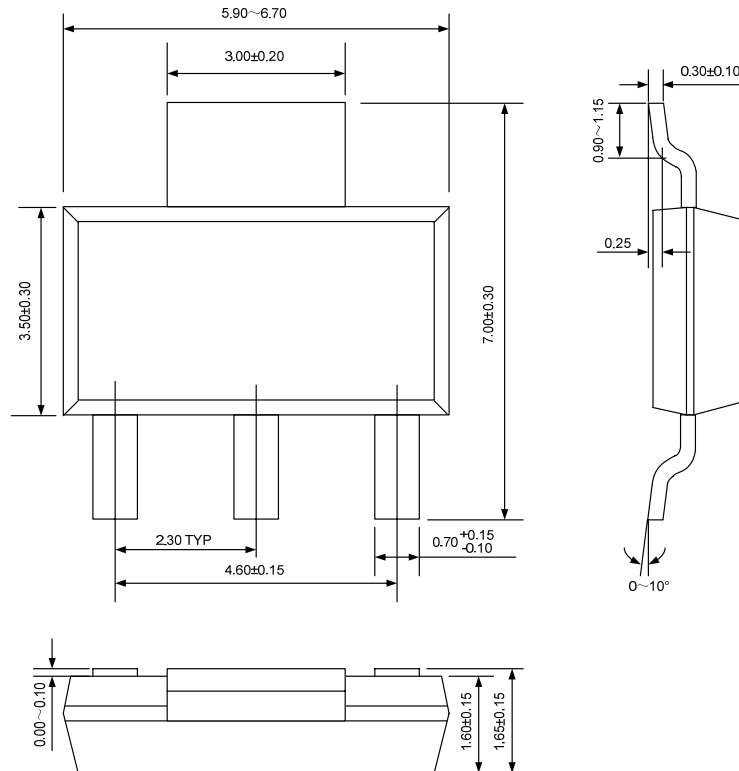

Disclaimer:

- Silan reserves the right to make changes to the information herein for the improvement of the design and performance without further notice! Customers should obtain the latest relevant information before placing orders and should verify that such information is complete and current.
- All semiconductor products malfunction or fail with some probability under special conditions. When using Silan products in system design or complete machine manufacturing, it is the responsibility of the buyer to comply with the safety standards strictly and take essential measures to avoid situations in which a malfunction or failure of such Silan products could cause loss of body injury or damage to property.
- Silan will supply the best possible product for customers!