

## 5A LDO VOLTAGE REGULATOR

### DESCRIPTION

The SA1084 is a positive low voltage dropout regulator, and the voltage dropout is 1.5V at 5A.

SA1084 provides two versions: fixed and adjustable versions. V<sub>OUT</sub> of fixed version has a tolerance of less than 1% for five kinds of output voltages 1.5V, 1.8V, 2.5V, 3.3V, and 5.0V.

The SA1084 offers some key features include thermal shutdown and current limiting. The SA1084 is an excellent choice for use in various electronic equipments.

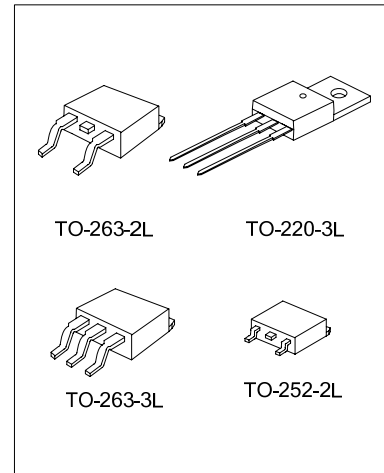

### FEATURES

- \* 1% accuracy in fixed version 1.5V, 1.8V, 2.5V, 3.3V, 5.0V and adjustable version
- \* Low Dropout Voltage: 1.5V at 5A output current
- \* Current Limiting: 6.5A
- \* Thermal Shutdown
- \* Line Regulation(Adj Version: Typical): 0.015%
- \* Load Regulation ( Adj Version: Typical): 0.1%
- \* Temperature Range: 0 to 125°C

### APPLICATIONS

- \* High Efficiency Linear Regulators
- \* Post Regulators for Switching Supplies
- \* Battery Charger
- \* Microprocessor Supply
- \* Desktop PCs, RISC and Embedded Processors Supply

### ORDERING INFORMATION (Temperature range: 0~125°C)

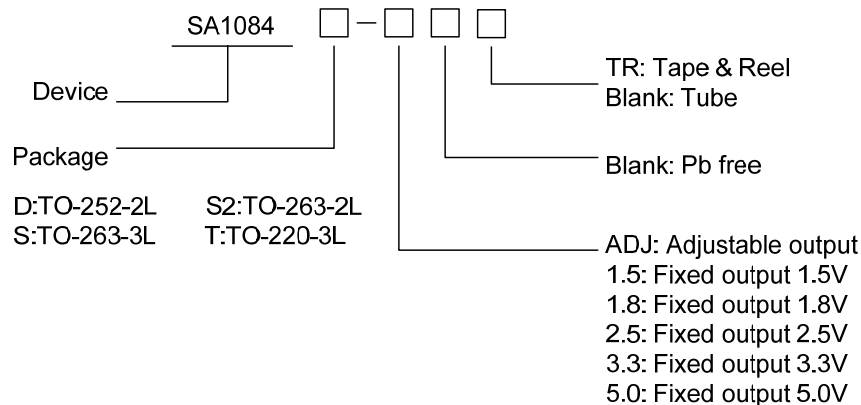

Part No.	Package	Marking	Material	Package Type
SA1084D-ADJ	TO-252-2L	SA1084D-ADJ	Pb free	Tube
SA1084D-ADJTR		SA1084D-ADJ	Pb free	Tape & Reel
SA1084D-1.5		SA1084D-1.5	Pb free	Tube
SA1084D-1.5TR		SA1084D-1.5	Pb free	Tape & Reel
SA1084D-1.8		SA1084D-1.8	Pb free	Tube
SA1084D-1.8TR		SA1084D-1.8	Pb free	Tape & Reel

Part No.	Package	Marking	Material	Package Type	
SA1084D-2.5	TO-252-2L	SA1084D-2.5	Pb free	Tube	
SA1084D-2.5TR		SA1084D-2.5	Pb free	Tape & Reel	
SA1084D-3.3		SA1084D-3.3	Pb free	Tube	
SA1084D-3.3TR		SA1084D-3.3	Pb free	Tape & Reel	
SA1084D-5.0		SA1084D-5.0	Pb free	Tube	
SA1084D-5.0TR		SA1084D-5.0	Pb free	Tape & Reel	
SA1084S-ADJ	TO-263-3L	SA1084S-ADJ	Pb free	Tube	
SA1084S-ADJTR		SA1084S-ADJ	Pb free	Tape & Reel	
SA1084S-1.5		SA1084S-1.5	Pb free	Tube	
SA1084S-1.5TR		SA1084S-1.5	Pb free	Tape & Reel	
SA1084S-1.8		SA1084S-1.8	Pb free	Tube	
SA1084S-1.8TR		SA1084S-1.8	Pb free	Tape & Reel	
SA1084S-2.5		SA1084S-2.5	Pb free	Tube	
SA1084S-2.5TR		SA1084S-2.5	Pb free	Tape & Reel	
SA1084S-3.3		SA1084S-3.3	Pb free	Tube	
SA1084S-3.3TR		SA1084S-3.3	Pb free	Tape & Reel	
SA1084S-5.0		SA1084S-5.0	Pb free	Tube	
SA1084S-5.0TR		SA1084S-5.0	Pb free	Tape & Reel	
SA1084T-ADJ		TO-220-3L	SA1084T-ADJ	Pb free	Tube
SA1084T-1.5			SA1084T-1.5	Pb free	Tube
SA1084T-1.8	SA1084T-1.8		Pb free	Tube	
SA1084T-2.5	SA1084T-2.5		Pb free	Tube	
SA1084T-3.3	SA1084T-3.3		Pb free	Tube	
SA1084T-5.0	SA1084T-5.0		Pb free	Tube	
SA1084S2-ADJ	TO-263-2L	SA1084S2-ADJ	Pb free	Tube	
SA1084S2-ADJTR		SA1084S2-ADJ	Pb free	Tape & Reel	
SA1084S2-1.5		SA1084S2-1.5	Pb free	Tube	
SA1084S2-1.5TR		SA1084S2-1.5	Pb free	Tape & Reel	
SA1084S2-1.8		SA1084S2-1.8	Pb free	Tube	
SA1084S2-1.8TR		SA1084S2-1.8	Pb free	Tape & Reel	
SA1084S2-2.5		SA1084S2-2.5	Pb free	Tube	
SA1084S2-2.5TR		SA1084S2-2.5	Pb free	Tape & Reel	
SA1084S2-3.3		SA1084S2-3.3	Pb free	Tube	
SA1084S2-3.3TR		SA1084S2-3.3	Pb free	Tape & Reel	
SA1084S2-5.0		SA1084S2-5.0	Pb free	Tube	
SA1084S2-5.0TR		SA1084S2-5.0	Pb free	Tape & Reel	

**BLOCK DIAGRAM**

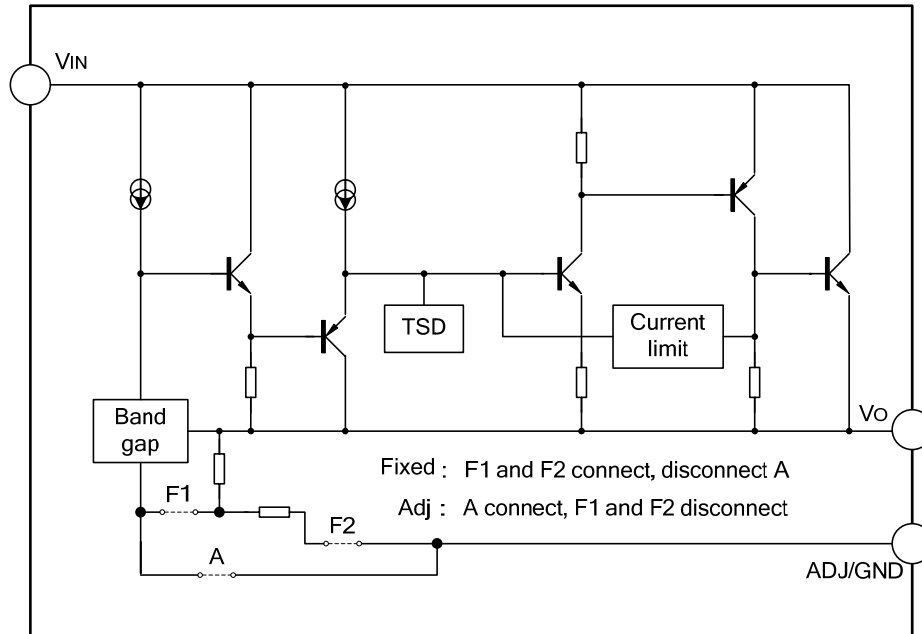

**ABOSOLUTE MAXIMUM RATINGS**

Characteristics	Symbol	Ratings	Unit
Input Supply Voltage	V <sub>IN</sub>	20	V
Lead Temperature (Soldering, 5 seconds)	T <sub>LEAD</sub>	260	°C
Operating Junction Temperature Range	T <sub>J</sub>	150	°C
Storage Temperature Range	T <sub>S</sub>	-65 ~ +150	V
Power Dissipation	PD	Internally Limited (note1)	mW
ESD Tolerance (Minimum)	ESD	2000	V

Note1: The maximum allowable power dissipation is a function of maximum operating junction temperature, T<sub>J</sub> (max), the junction to ambient thermal resistance, θ<sub>JA</sub>, and the ambient temperature T<sub>amb</sub>. The maximum allowable power dissipation at any ambient temperature is given: PD (max) = (T<sub>J</sub> (max) – T<sub>amb</sub>)/θ<sub>JA</sub>, exceeding the maximum allowable power limit will result in excessive die temperature; thus, the regulator will go into thermal shutdown. The junction to ambient thermal resistance, θ<sub>JA</sub> of some packages may be different; the value of θ<sub>JA</sub> depends on mounting technique.

**RECOMMENDED OPERATING CONDITIONS**

Characteristics	Symbol	Ratings	Unit
Input voltage	V <sub>IN</sub>	12	V
Operating Junction Temperature Range	T <sub>J</sub>	0 ~ +125	°C

**ELECTRICAL CHARACTERISTICS** ( $T_{amb}=25^{\circ}\text{C}$ , unless otherwise specified. Limits appearing in Boldface type apply over the entire junction temperature range for operation,  $0^{\circ}\text{C}$  to  $125^{\circ}\text{C}$ .)

Characteristics	Symbol	Conditions	Min.	Typ.	Max.	Unit
Reference Voltage	VREF	SA1084-ADJ, $I_{OUT}=10\text{mA}$ , $V_{IN}-V_{OUT}=3\text{V}$ , $10\text{mA}\leq I_{OUT}\leq 5\text{A}$ , $1.5\text{V}\leq V_{IN}-V_{OUT}\leq 5\text{V}$	1.238 1.225	1.250 1.250	1.262 1.270	V
Output Voltage	VOUT	SA1084-1.5, $I_{OUT}=10\text{mA}$ , $V_{IN}=4.5\text{V}$ , $10\text{mA}\leq I_{OUT}\leq 5\text{A}$ , $3.0\text{V}\leq V_{IN}\leq 6\text{V}$	1.485 1.47	1.5 1.5	1.515 1.53	V
		SA1084-1.8, $I_{OUT}=10\text{mA}$ , $V_{IN}=4.8\text{V}$ , $10\text{mA}\leq I_{OUT}\leq 5\text{A}$ , $3.3\text{V}\leq V_{IN}\leq 6\text{V}$	1.782 1.764	1.8 1.8	1.818 1.836	V
		SA1084-2.5, $I_{OUT}=10\text{mA}$ , $V_{IN}=5.5\text{V}$ $10\text{mA}\leq I_{OUT}\leq 5\text{A}$ , $4.0\text{V}\leq V_{IN}\leq 7\text{V}$	2.475 2.45	2.5 2.5	2.525 2.55	V
		SA1084-3.3, $I_{OUT}=10\text{mA}$ , $V_{IN}=6.3\text{V}$ , $10\text{mA}\leq I_{OUT}\leq 5\text{A}$ , $4.8\text{V}\leq V_{IN}\leq 8\text{V}$	3.267 3.234	3.3 3.3	3.333 3.366	V
		SA1084-5.0, $I_{OUT}=10\text{mA}$ , $V_{IN}=8\text{V}$ , $10\text{mA}\leq I_{OUT}\leq 5\text{A}$ , $6.5\text{V}\leq V_{IN}\leq 10\text{V}$	4.95 4.9	5 5	5.05 5.1	V
		SA1084-ADJ, $I_{OUT}=10\text{mA}$ , $2.85\text{V}\leq V_{IN}\leq 10\text{V}$		0.015 0.035	0.2 0.2	%
Line Regulation	$\Delta V_{OUT}$	SA1084-1.5, $I_{OUT}=10\text{mA}$ , $3.0\text{V}\leq V_{IN}\leq 10\text{V}$		0.5 1	6 6	mV
		SA1084-1.8, $I_{OUT}=10\text{mA}$ , $3.3\text{V}\leq V_{IN}\leq 10\text{V}$		0.5 1	6 6	mV
		SA1084-2.5, $I_{OUT}=10\text{mA}$ , $4.0\text{V}\leq V_{IN}\leq 10\text{V}$		0.5 1	6 6	mV
		SA1084-3.3, $I_{OUT}=10\text{mA}$ , $4.8\text{V}\leq V_{IN}\leq 10\text{V}$		0.5 1	6 6	mV
		SA1084-5.0, $I_{OUT}=10\text{mA}$ , $6.5\text{V}\leq V_{IN}\leq 10\text{V}$		0.5 1	10 10	mV
		SA1084-ADJ, $0\text{mA}\leq I_{OUT}\leq 5\text{A}$ , $V_{IN}-V_{OUT}=3\text{V}$		0.1 0.2	0.3 0.4	%
Load Regulation	$\Delta V_{OUT}$	SA1084-1.5, $0\text{mA}\leq I_{OUT}\leq 5\text{A}$ , $V_{IN}-V_{OUT}=3\text{V}$		3 7	15 20	mV
		SA1084-1.8, $0\text{mA}\leq I_{OUT}\leq 5\text{A}$ , $V_{IN}-V_{OUT}=3\text{V}$		3 7	15 20	mV
		SA1084-2.5, $0\text{mA}\leq I_{OUT}\leq 5\text{A}$ , $V_{IN}-V_{OUT}=3\text{V}$		3 7	15 20	mV
		SA1084-ADJ, $0\text{mA}\leq I_{OUT}\leq 5\text{A}$ , $V_{IN}-V_{OUT}=3\text{V}$		0.1 0.2	0.3 0.4	%

Characteristics	Symbol	Conditions	Min.	Typ.	Max.	Unit
Load Regulation	$\Delta V_{OUT}$	SA1084-3.3, $0mA \leq I_{OUT} \leq 5A$ , $V_{IN} - V_{OUT} = 3V$		3 7	15 20	mV
		SA1084-5.0, $0mA \leq I_{OUT} \leq 5A$ , $V_{IN} - V_{OUT} = 3V$		5 10	20 35	mV
Dropout Voltage	$V_{DROP}$	$I_{OUT} = 5A$ , $\Delta V_{REF}$ , $\Delta V_{OUT} = 1\%$		1.45	1.5	V
Current Limit	$I_{LIMIT}$	$V_{IN} - V_{OUT} = 3V$	5.5	6.5		A
Minimum Load Current	$I_{LOAD (MIN)}$	$V_{IN} = 10V$ (SA1084-ADJ)		3	10	mA
Quiescent Current	$I_Q$	$V_{IN} = 10V$ (SA1084)		5	10	mA
Ripple Rejection	PSRR	fRIPPLE=120Hz, $C_{OUT} = 25\mu F$ Tantalum, $I_{OUT} = 5A$ , $V_{IN} - V_{OUT} = 3V$	60	72		dB
Adjust Pin Current	$I_{ADJ}$	$V_{IN} = 4.25V$ , $I_{OUT} = 10mA$		55	120	$\mu A$
Adjust Pin Current Change	$\Delta I_{ADJ}$	$10mA \leq I_{OUT} \leq 5A$ , $1.5V \leq (V_{IN} - V_{OUT}) \leq 4.5V$		0.2	5	$\mu A$
Temperature Stability		$I_{OUT} = 10mA$ , $V_{IN} - V_{OUT} = 1.5V$		0.5		%
Long Term Stability		$T_{amb} = 125^\circ C$ , 1000Hrs		0.5		%
RMS Noise (% of $V_{OUT}$ )		$10Hz \leq f \leq 10kHz$		0.003		%
Thermal Resistance	$\theta_{JA}$	TO-263-3L		60		$^\circ C/W$
		TO-263-2L		60		
		TO-220-3L		60		
		TO-252-2L		100		

## PIN CONFIGURATION

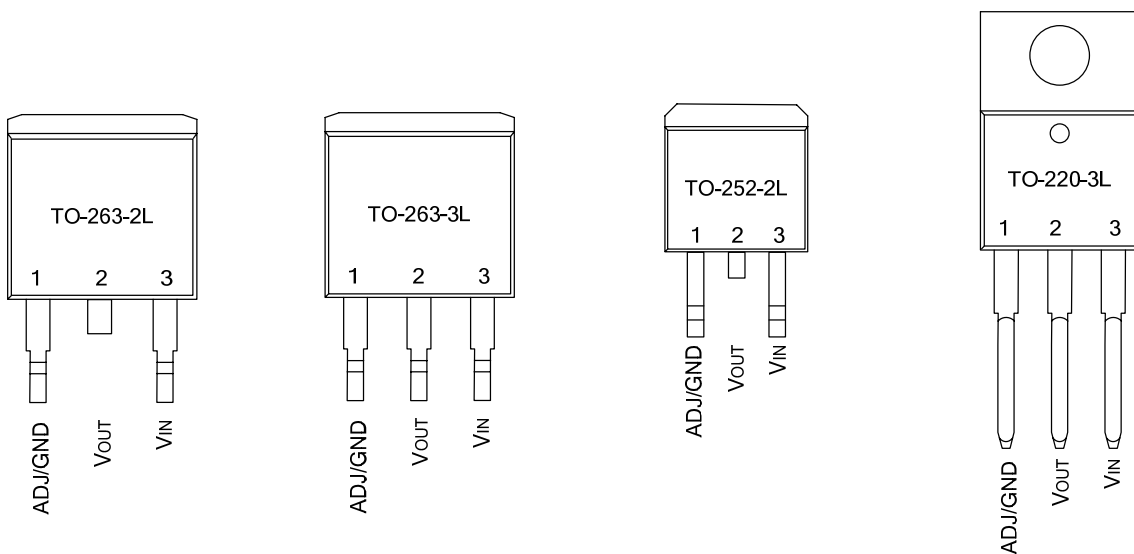

**PIN DESCRIPTION**

Pin No.	Pin name	I/O	Functions
1	GND/ADJ	G/O	Ground/ADJ
2	VOUT	O	Output voltage
3	VIN	I	Input supply voltage

**FUNCTION DESCRIPTION**

The SA1084 is a LDO regulator, its pass transistor is made up of a single NPN transistor being driven by a PNP. The dropout voltage is defined as:  $V_{DROP} = V_{BE} + V_{SAT}$ .

The SA1084 series of fixed and adjustable regulators are easy to use. Output voltages are 1.5V, 1.8V, 2.5V, 3.3V, and 5.0V. On-chip thermal shut down provides protection against any combination of overload and ambient temperature that would create excessive junction temperature.

The SA1084 requires an output capacitor for device stability. Its value of 22μF tantalum covers all cases of bypassing the adjustment terminal. Without bypassing the adjustment terminal smaller capacitors can be used with equally good results .depends upon the application circuit. In general, linear regulator stability decreases with higher output currents.

**TYPICAL APPLICATION CIRCUIT**

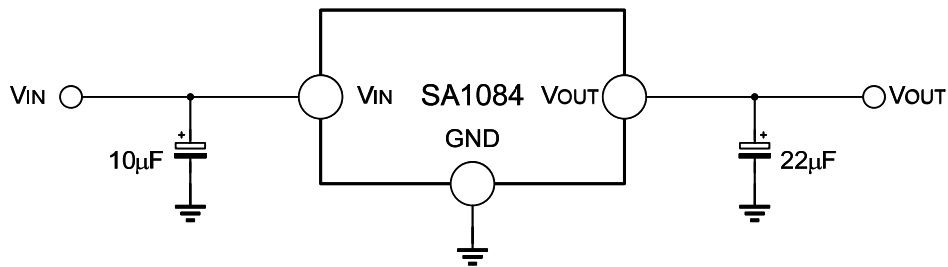

Figure 1. Typical Fixed Output Voltage

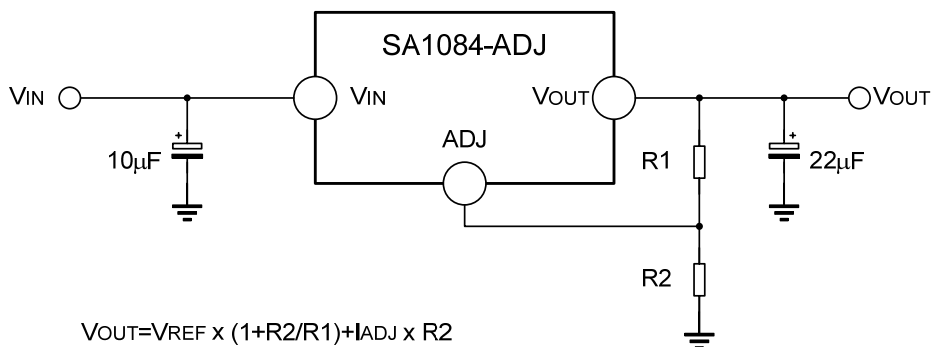
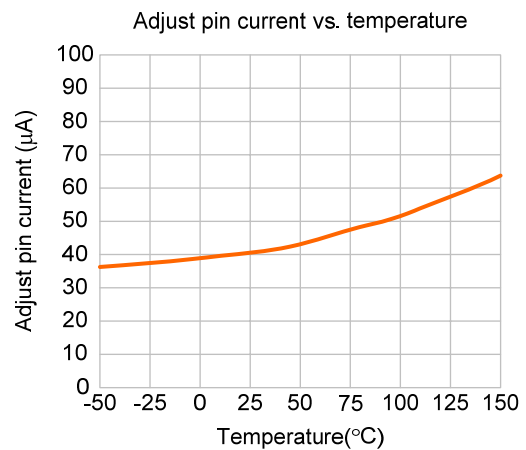
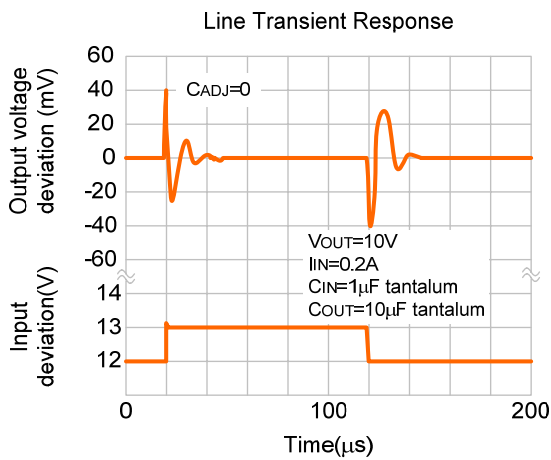
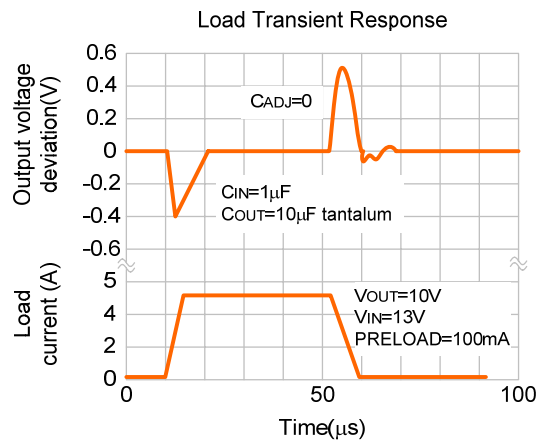
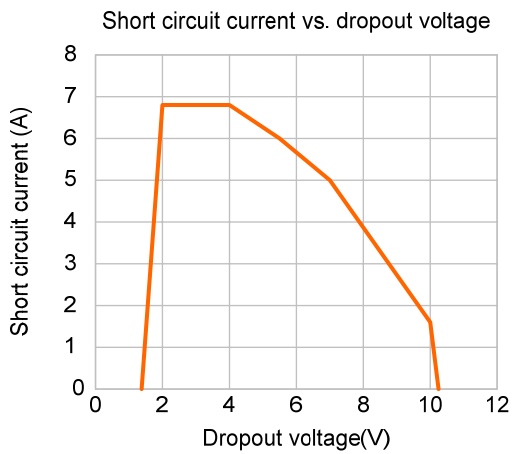
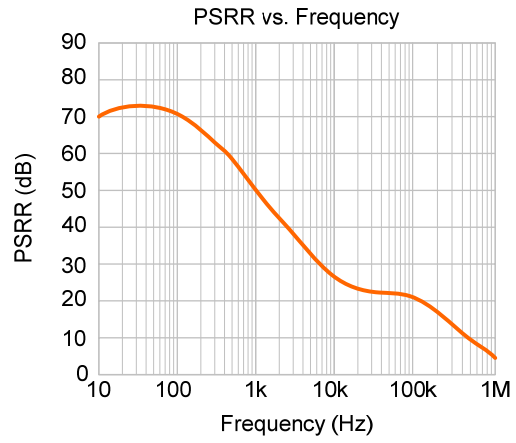
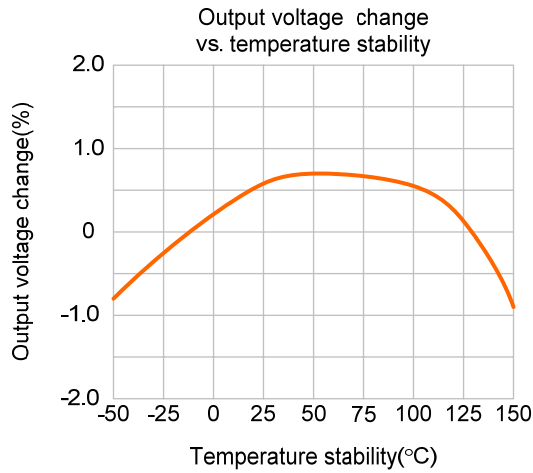

Figure 2. Typical Adjustable Output Voltage

Note: The circuit and parameters are reference only, please set the parameters of the real application circuit based on the real test.

TYPICAL CHARACTERISTICS CURVES



PACKAGE OUTLINE

TO-252-2L

UNIT: mm

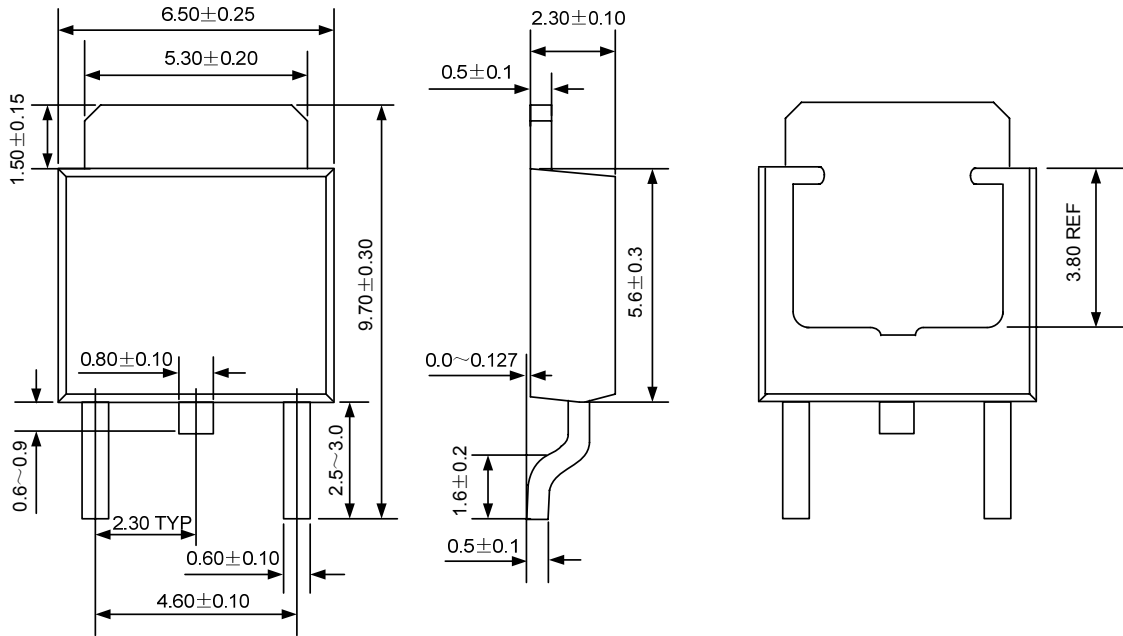

TO-252-2L

UNIT: mm

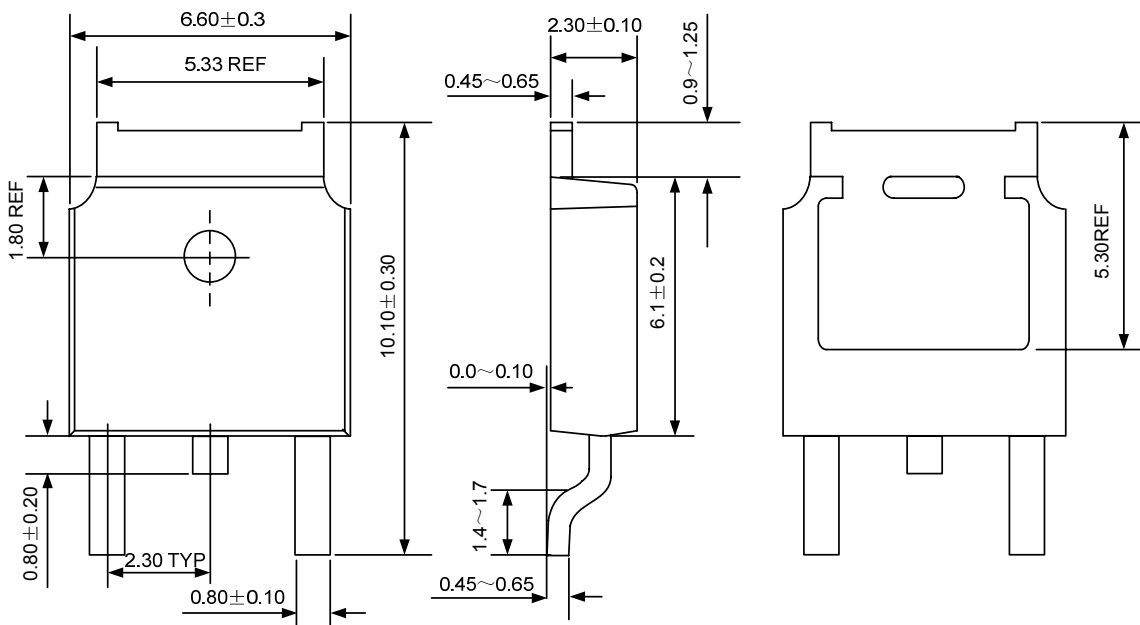



PACKAGE OUTLINE

TO-220-3L

UNIT: mm

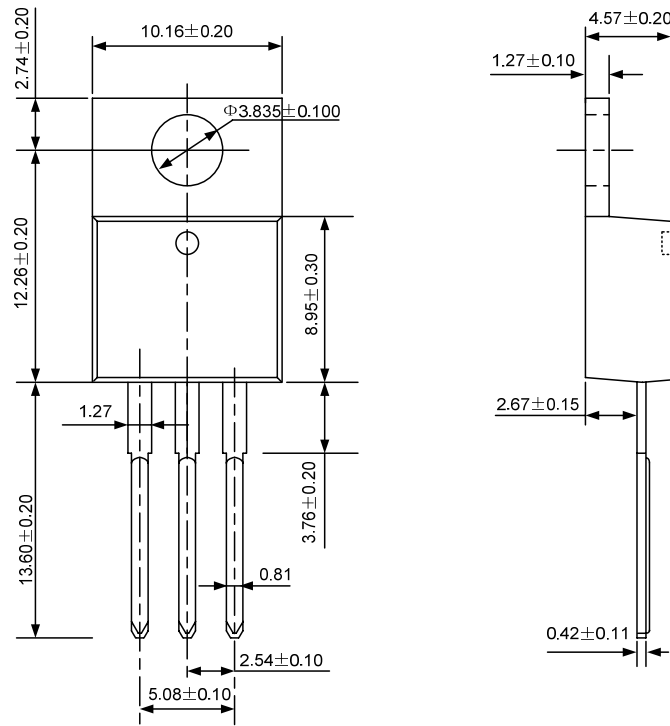

TO-263-2L

UNIT: mm

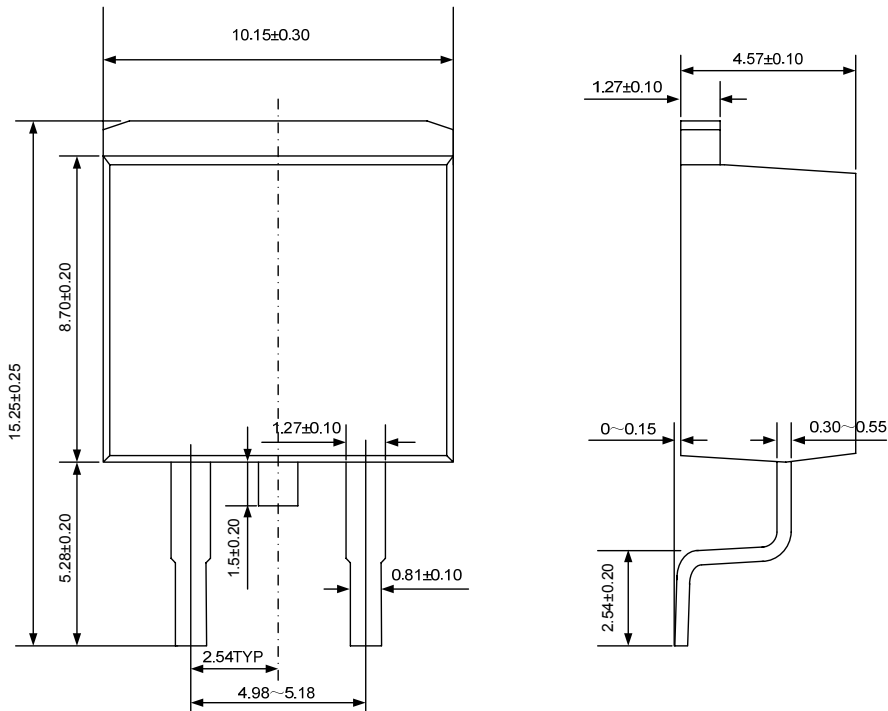

PACKAGE OUTLINE

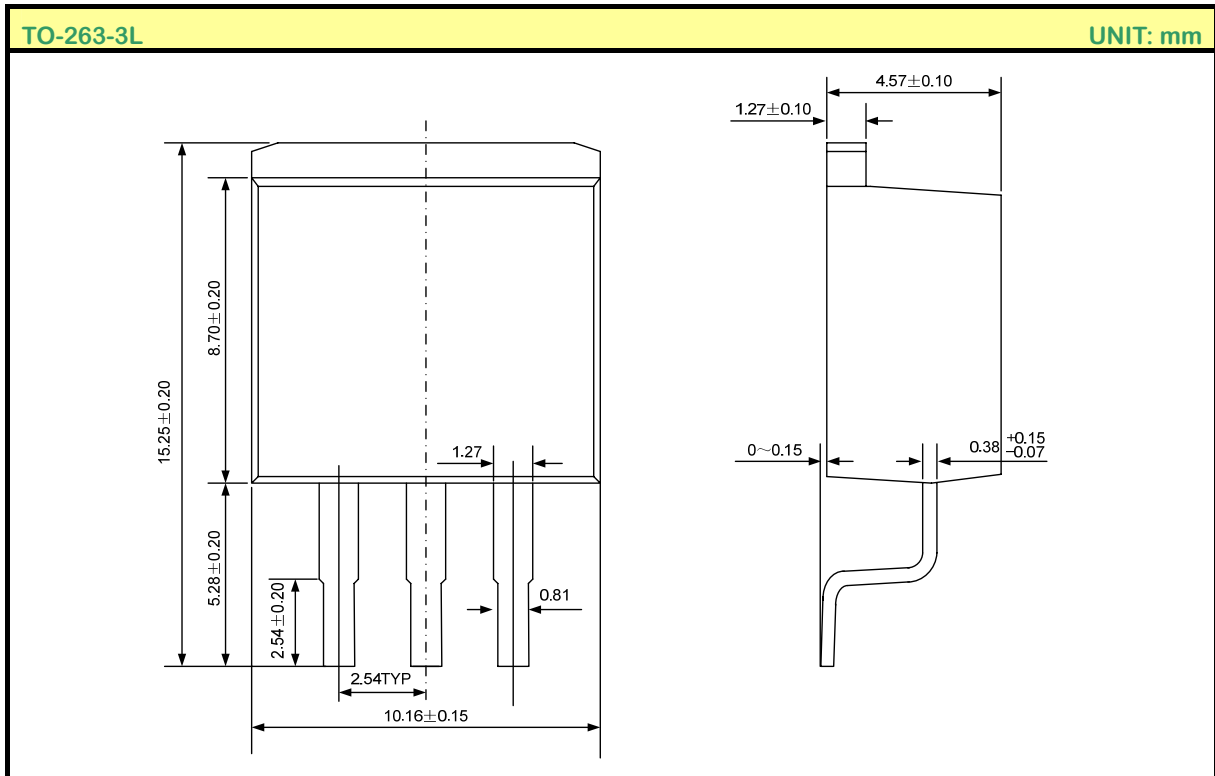

Disclaimer:

- Silan reserves the right to make changes to the information herein for the improvement of the design and performance without further notice!
- All semiconductor products malfunction or fail with some probability under special conditions. When using Silan products in system design or complete machine manufacturing, it is the responsibility of the buyer to comply with the safety standards strictly and take essential measures to avoid situations in which a malfunction or failure of such Silan products could cause loss of body injury or damage to property.
- Silan will supply the best possible product for customers!